



Item: \_\_\_\_\_  
 Quantity: \_\_\_\_\_  
 Project: \_\_\_\_\_  
 Approval: \_\_\_\_\_  
 Date: \_\_\_\_\_

Induction Green Heat  
 Garland Induction Counter Unit 3.5kW and 5.0kW

# Induction Green Heat

## Garland Induction Counter Unit 3.5kW and 5.0kW

Models:

GI-SH/BA 3500

GI-SH/BA 5000



### Induction Benefits:

- Energy Efficient
- Fast Heat
- Precise Cooking
- Easy To Clean
- No Pan, No Heat.
- Cool Operations
- Boil Dry Protection

### Standard Features:

- Compact table top design with stainless steel body and high impact ceramic glass top
- Sloped, easy to see front panel with adjustable control for easy operation
- Integral cooling fan keeps electronics cool, discharging from rear with protective air deflectors preventing hot exhaust to be pulled back into unit
- Removable, reusable easy to clean air intake filter
- 6' (1829mm) cord and plug supplied (60 cycle units only)
- "Flat Design", compact high performance electronics allow for low unit heights
- Instant energy transmission to the pan
- Available in either 3.5kW or 5.0kW
- Thermostatically controlled overheat sensor shuts the unit off to prevent damage from pans cooking dry
- Induction technology transfers heat to the pan, not to the surrounding air, allowing for cool operation
- Innovated new technology for pan detection; RTCS is an internal control software development matching speed, capability and performance.
  - R – Real Time
  - T – Temperature
  - C – Control
  - S – System
- Electronic output limitation continually monitors the energy transfer to the pan, helping to ensure the most efficient energy transfer possible.

### Specifications:

Shall be a Garland Induction Unit model GI-SH/BA 3500 with a total kW rating of 3.5 kW or model GI-SH/BA 5000 with a total kW rating of 5.0 kW. Built with a robust stainless steel casting with a Ceran glass work top. Compact powerful electronic system for years of reliable service. Overheat sensors prevent damage of the unit if pan is run dry. Easy to operate rotary switch with 1 to 12 scale. Units to come in 208V or 240V power (specify at the time of order) with integral cord and plug for North America.

Note: Induction cooking requires "Induction Ready" pans to operate.



Intertek



CE models comply with the latest European Norms: EN 60335-1, EN 60335-2-36, EN 62233 (EMC/EMV)

North American models:  
 ETL listed in compliance with  
 UL 197, CSA C22.2 No.109, NSF-4  
 Complies with FCC part 18, ICES-001



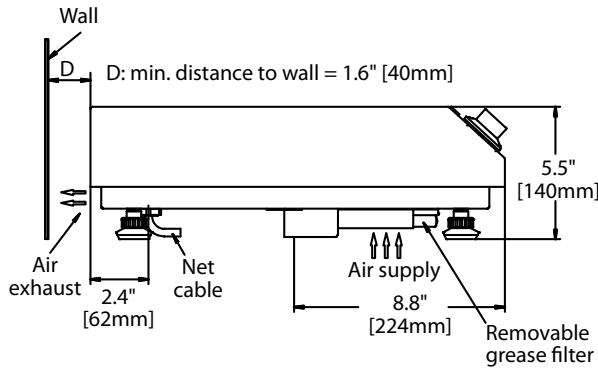
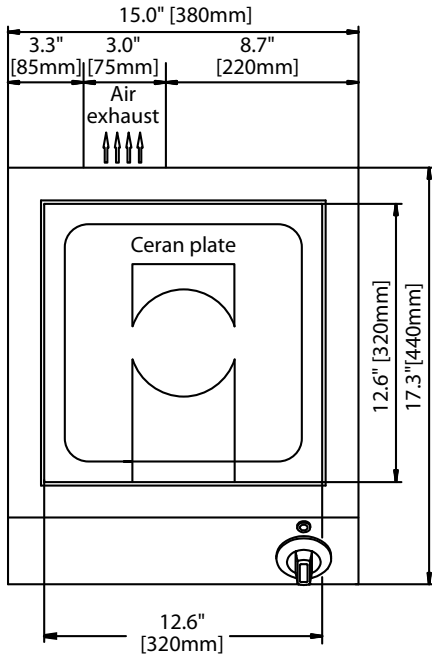

Garland/U.S. Range products are not approved or authorized for home or residential use, but are intended for commercial applications only. Garland / U.S. Range will not provide service, warranty, maintenance or support of any kind other than in commercial applications.

Electrical Loading				
Model	Watts	208/60/1	240/60/1	230/50/1
GI-SH/BA 3500	3500	17 amp	14 amp	15 amp

Electrical Loading				
Model	Watts	208/60/3	400/50/3	440/50/3
GI-SH/BA 5000	5000	14 amp	8 amp	7 amp

**Plug Configurations**

Model	Electrical Characteristics	Plug
GI-SH/BA 3500	208V/60Hz/1Ø 240V/60Hz/1Ø	 NEMA 6-20P
	230V/50Hz/1Ø	 EU1-16P
GI-SH/BA 5000	208V/60Hz/3Ø	 NEMA 15-20P
		 NEMA L15-20P
	400V/50Hz/3Ø	 EU 5-Pole
	440V/50Hz/3Ø	Plug not included

Form# GI-SH/BA 3500/5000 (05/06/13)