



Master Series Heavy Duty Combination Top Range

Item: _____
 Quantity: _____
 Project: _____
 Approval: _____
 Date: _____

Master Series Heavy Duty Combination Top Range

Models:

- M42R M42S M42T

Range with 17" Valve Control Griddle and Two Open Burners



Model M42R

Standard Features:

- Stainless steel front and sides
- 6" (152mm) chrome steel adj. legs
- 7-1/2" (191mm) stainless steel front rail
- (2) 35,000 BTU (10.25kW), natural gas or 32,000 (9.37kW) propane; 2-piece Starfire open burners w/removable heads
- Removable ring grates over each burner & cast iron top grates
- Stainless steel drip tray under open burners
- Griddle with 1" (25mm) thick steel plate on left, with 33,000 BTU (9.66kW) "H" type burner controlled by Hi-Lo valve
- 2-5/16" (59mm) high welded steel splash guards, sides & back for griddle
- Clip-on stainless steel backsplash for griddle plate
- Removable front-mounted stainless steel grease receptacle
- Fully porcelainized oven interior
- Piezo Spark ignition for oven
- 40,000 BTU (11.72 kW) natural gas, 35,000 BTU (10.25 kW) propane gas cast iron oven burner

- Stainless steel common front rail up to 102" (2590mm) wide (2 or more units in a battery)
- Fully grooved griddle (or grooved sections)
- Convection oven base, add C to model #, e.g. M42RC
- Additional oven rack
- Rear gas connection, 3/4", 1", or 1-1/4" NPT
- Gas regulator 3/4" or 1-1/4"
- Gas shut off valve; 3/4", 1" or 1-1/4" NPT
- Gas flex hose & quick disconnect (3/4", 1" or 1-1/4" NPT x 5') w/restraining device, please specify
- End caps and cover (NC, Specify)
- Set of (4) Polurethane non-marking swivel casters with front brakes
- 6" (152mm) stainless steel adj. legs
- Dais base (not for use with "RC" oven)
- Stainless steel tubular high shelf, single or double deck
- Stainless steel backguard: 10" (354mm), 17" (432mm) or 33" (838mm)
- 230 volt, 50 cycle components, RC motor (export)
- Celsius dial for oven thermostat (NC)

Optional Features:

- Stainless steel oven interior
- Stainless steel main back

Specifications:

Heavy-duty combination top gas range with oven, One 17" (432mm) W x 25" (635mm) D, 1" (25mm) thick, Hi-Lo valve griddle on left, 33,000 BTU (9.6kW), bordered side and rear by continuously welded stainless steel splash guard. Two 35,000 BTU (10.25kW) Starfire open burners with removable heads. Heavy duty cast iron top grates/ring grates on right only, 34" (864mm) W x 38" (965mm) D, including 7-1/2" (191mm) deep stainless steel front rail. Porcelain enamel oven interior with 40,000 BTU (11.72kW) cast iron burner. Stainless steel front and sides. Natural or propane gas. Also available with storage base w/ doors, suffix S, and modular top, suffix T.



NOTE: Ranges supplied with casters must be installed with an approved restraining device.



Product	Width: In(mm)	Depth: In(mm)	Height: In(mm) (w/ NSF Legs)	Height: In(mm) (w/o NSF Legs)	Oven/Storage Base Interior: in(mm)		
					Width	Depth	Height
M42R	34(864)	38(965)	36-3/8(924)	30-3/8(772)	26-1/4(667)	29(737)**	13-1/2(343)
M42S	34(864)	38(965)	36-3/8(924)	30-3/8(772)	26(665)	30-1/2(773)	20-1/2(519)
M42T	34(864)	38(965)	36-3/8(924) w/stand	9-1/2(241) w/o stand*	N/A	N/A	N/A

*Modular top has 1-1/2" seating flanges. **RC oven is 25" (635mm) deep.

INPUT-BTU/hr	M42R & M42RC		M42S & M42T	
	Natural	Propane	Natural	Propane
Griddle Top	33,000 (9.60kW)	33,000 (9.60kW)	33,000 (9.60kW)	33,000 (9.60kW)
Open Burners	70,000 (20.50kW)	64,000 (18.74kW)	70,000 (20.50kW)	64,000 (18.74kW)
Oven	40,000 (11.72kW)	35,000 (10.25kW)	N/A	N/A
Total	143,000 (41.82kW)	132,000 (38.59kW)	103,000 (30.10kW)	97,000 (28.34kW)

RC=Range w/Convection Oven R=Range w/Oven S=Range w/Storage Base T=Modular Top

INSTALLATION NOTES			Shipping Wt: (Lb/Kg) ²	
Combustible Wall Clearances ¹	Entry Clearances	Operating Pressure	MST42R	520/326
Sides: 11" (279mm) Back: 6" (152mm)	Crated: 39-1/4"(997mm) Uncrated: 34-1/4" (870mm)	Natural: 6" WC (15mbar) Propane: 10" WC (25mbar)	MST42S	420/191
			MST42T	330/150

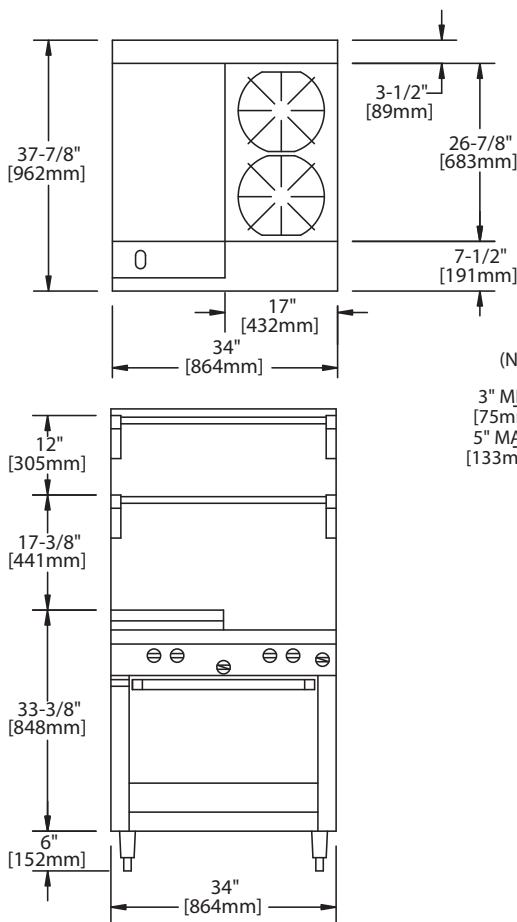

¹NOTE: Installation clearance reductions are applicable only where local codes permit.

²Shipping Cubic Feet 50 for R & S Models, 20 for T models

Data applies only to North America

Gas input ratings shown here are for installations up to 2,000 ft. (610m) above sea level. Specify altitudes over 2,000 ft.

Electrical characteristics each RC oven: 1/3 HP motor, 120 VAC, single phase, 3.4 amps, 6 ft. (1.8m) power cord with NEMA 5-15P plug provided. 230 VAC export is direct connect, single phase, 50 Hz.

Please specify gas type when ordering.

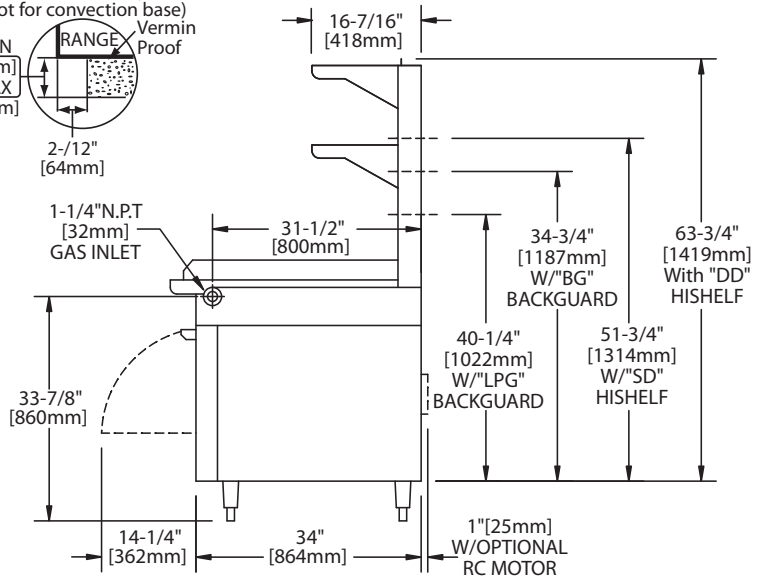
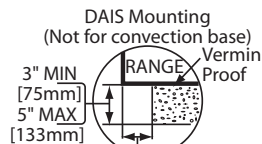

Form# M42 (04/08/13)