



Induction Green Heat

Garland Induction Built-in Unit RTCsmp Module-Line "Two Cooking Zones"

Item: _____
 Quantity: _____
 Project: _____
 Approval: _____
 Date: _____

Models:

- GI-MO/DU 14000-650FL GI-MO/DU 14000-720FL

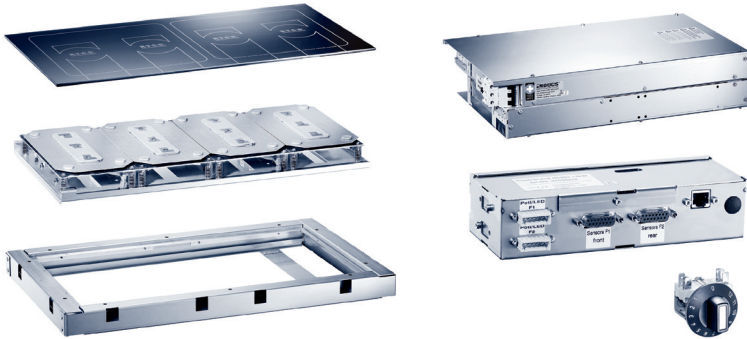

Garland Modular Induction built-in concept with two cooking zones consisting of:

Induction generator, coil carrier sheet with coils and sensors, Ceran glass, control unit, as well as operation and cable kit.

Equipped with the latest RTCsmp (Realtime Temperature Control System) technology.

Standard Features

Induction generator:

A powerful generator that is fully integrated in an enclosed housing and equipped with an integrated fan.

All connections such as the mains cable, operation, CAN cable and sensor cable can be connected externally through plug connections.

The generator is equipped with an air ducting system, through which the heated air is exhausted. Using this design, the risk of a thermal short-circuit is reduced.

Control unit:

The control unit is the information and diagnostic hub for the whole induction unit. It is connected with the generator via RJ45 cable. Compact design and easy to install using special installation tabs/brackets.

Operation unit:

The power switch regulates the temperature in power levels 1 to 12. Simple to operate; adjust the temperature setting simply by turning the knob.

Mounting Frame:

Installation/mounting frame is included with unit.

Coil Carrier Sheet:

Compact design with induction coils and sensors. Engineered specifically for modular kitchen designs.

Full Coil (FL): Rectangular in shape. Several large or small pans can be placed on one surface at the same time.

Safety above all:

- RTCsmp electronic temperature control that monitors the state of the induction coils, ceramic glass, heat sink and electronics.
- RTCsmp monitors the energy supply.
- Using a special control, interference noises are prevented when operating multiple cooking zones.
- Limiting the energy supply at peak load.
- Automatic monitoring when not cooking, also when using pans with a sandwich base.
- IR interface with diagnostic system.

Optional Features

- Cable kit: 4m (SKU# 95000246) or 6 m (SKU# 95000247).



CE models comply with the latest European Norms: EN 60335-1, EN 60335-2-36, EN 62233 (EMC/EMV)

North American models:

ETL listed in compliance with UL 197, CSA C22.2 No.109, NSF-4
Complies with FCC part 18, ICES-001

Garland Commercial Ranges Ltd.
1177 Kamato Road,
Mississauga, Ontario
L4W 1X4 CANADA

General Inquiries 1-905-624-0260
USA Sales, Parts and Service 1-800-424-2411
Canadian Sales 1-888-442-7526
Canada or USA Parts/Service 1-800-427-6668



Induction Green Heat
Garland Induction Built-in Unit RTCsmp Module-Line "Two Cooking Zones"

Induction Generator IN/GI-MO 14000FL

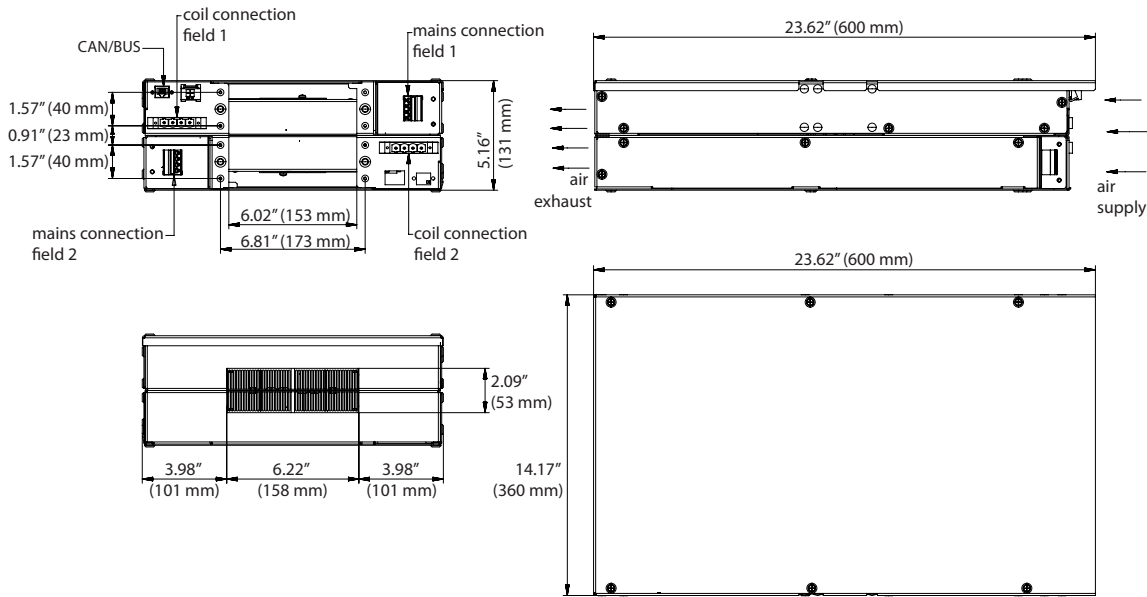

Control Unit IN/GI-MO 14000

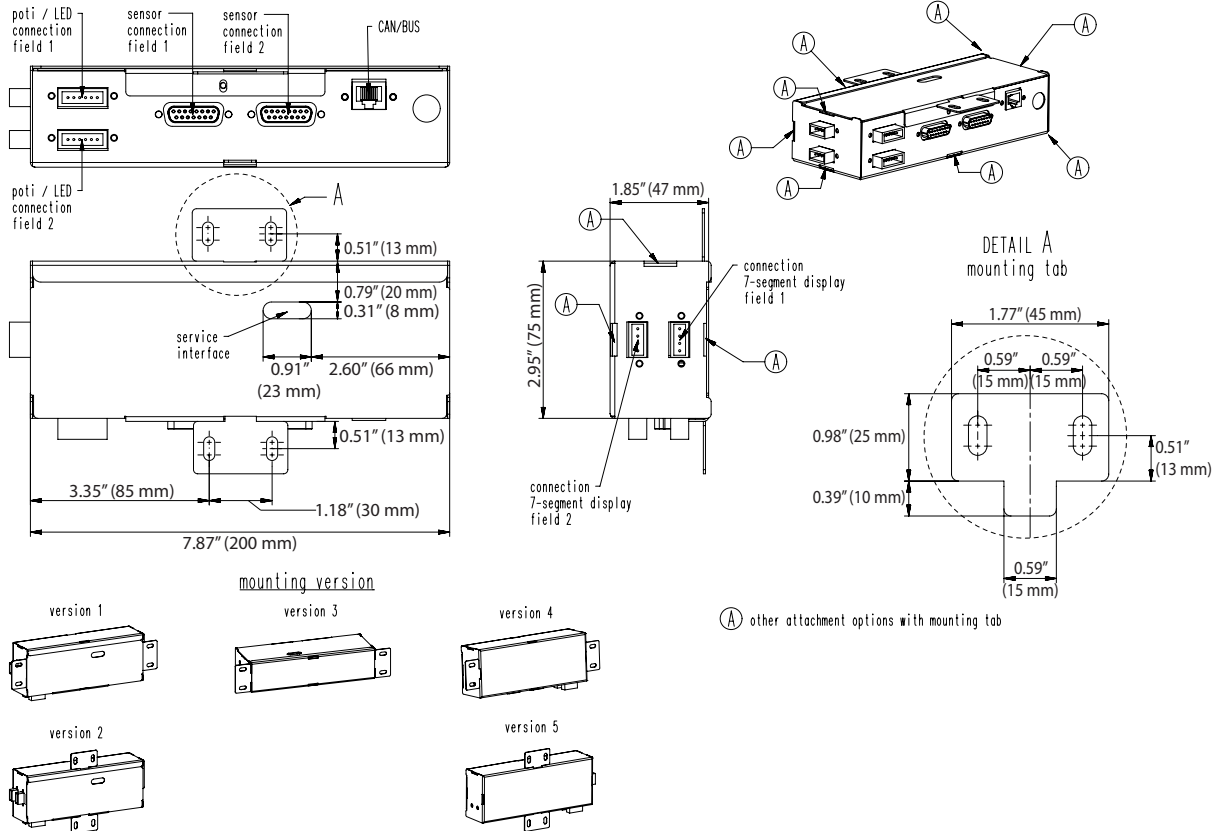

Mounting Frame 375 X 650 mm

measurements in mm and [inch]

M4 thread (10x)
to adjust the
ceran glass

M4 thread (6x)
to adjust the
coil carrier sheet

installation
frame

holding rail

Model	Ceran Glass Inch (mm)	Mounting Frame Inch (mm)	Number of Coils	Size of Coils Inch (mm)	Power per Cooking Zone	Number of Cooking Zones	Total Rating
GI-MO/DU 14000-650FL	14.76x25.60x0.24 (375 x 650 x 6)	14.76x25.60 (375 x 650)	4	5.67x11.02 (144 x 280)	7.0 kW	2	14.0 kW
GI-MO/DU 14000-720FL	14.17x28.35x0.24 (360 x 720 x 6)	14.17x28.35 (360 x 720)	4	5.91x11.42 (150 x 290)	7.0 kW	2	14.0 kW

Technical Data

Generator housing: 23.62x14.17x5.16" (600 x 360 x 131 mm)

Network impedance (Zmax): 0.25 Ω

Air flow fan: 4238 ft³/h (120 m³/h maximum)

Cut out for air supply: 10.08 sq. in (6500 mm², min)

Cable Kit: 8.2 ft (2.5 m)

Garland/ U.S. Range products are not approved or authorized for home or residential use, but are intended for commercial applications only. Garland/ U.S. Range will not provide service, warranty, maintenance or support of any kind other than in commercial applications.

Electrical Loading

Model	Watts	208/60/3	400/50/3	440/50/3
GI-MO/DU 14000	14000	22 amp	11 amp	10 amp

Form# GI-MO/DU 14000-650/720FL (12/19/13)