

Item: _____
 Quantity: _____
 Project: _____
 Approval: _____
 Date: _____

SCO Series Electric Convection Oven

Models:

- SCO-ES-10S SCO-ES-20S



SCO-ES-10S

Note: Ovens supplied with casters must be installed with an approved restraining device.

Standard Features:

- SUNFIRE Series Solid State control with electro-mechanical timer
- Single speed fan control with 3/4 HP fan motor
- Total of 10.4 kW loading per oven cavity
- Stainless steel front, sides, top, and legs
- 60/40 dependent solid door design
- Porcelain enameled oven interior with coved corners
- Five (5) chrome plated oven racks on 10-position rack guides
- Double deck models available.
- One year limited parts and labor warranty (USA and Canada only)
- Three year limited door warranty (USA and Canada only)

Optional Features:

- Two speed fan
- Two speed fan windows in left door and interior oven lights.
- Extra oven racks
- Swivel casters, (4) w/ front brakes
- Low profile casters, (4) w/ front brakes (double ovens only)
- Open base with rack guides and shelf (stainless steel)
- Back enclosure (stainless steel)

Specifications:

SUNFIRE Full-Size Standard Depth electric convection oven. 10.4 kW/cavity, 3/4 HP single-speed fan motor. Electronic spark ignition. Solid State Control with 60-minute timer. Porcelain enameled oven interior with coved corners, five (5) oven racks and 10 position rack guides. All model interiors are 29" (736mm) wide by 24" (610mm) deep. Stainless steel front, sides, top and legs. 60/40 dependent solid door design. Models with the 20S suffix are double deck units. UL, CUL and NSF listed.



Model	Int. Dimensions :In (mm)			Ext. Dimensions: In (mm)			Ship Wt	Ship Dim.
	W	H	D	W	H**	D (w/motor)	Lbs/kg	Cubic Ft.
SCO-ES-10S	29 (736)	24 (610)	24 (610)	38 (965)	57-1/2 (1461)	41-1/4 (1048)	750/341	80
SCO-ES-20S	29(736)	24(610)	24(610)	38(965)	70-1/2 (1791)	41-1/4 (1048)	1500/682	160

** Height with or without standard casters. Height with low profile casters (double deck) is 68-1/2" (1740mm).

Model	Total kW	Nominal Amperes Per Line, (includes 3/4 HP fan motor)							
		208V/1Ph	240V/1Ph	208V/3Ph			240V/3Ph		
				X	Y	Z	X	Y	Z
Single Deck	10.4	50	43	30	30	28	26	26	24
Double Deck* each oven	10.4	50	43	30	30	28	26	26	24

* Double Deck Models require individual power supply connections

Electrical specifications include motor requirements. 3/4, HP, 1-speed motor: 1725rpm or optional 2-speed 1725/1140 rpm, (60Hz); Please specify electrical characteristics when ordering.

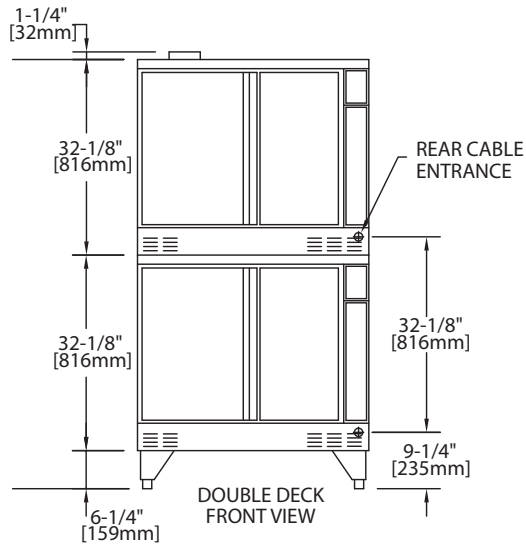
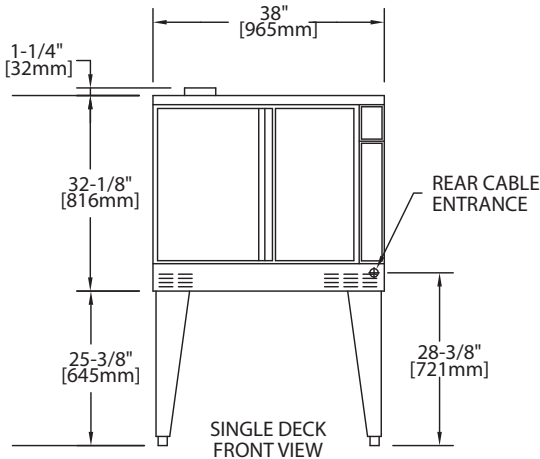
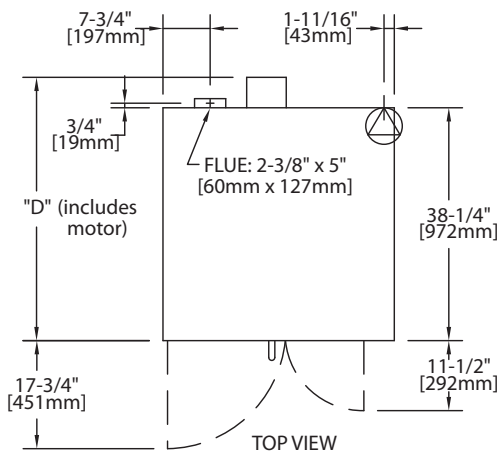

Installation Notes:			
Combustible & Non-Combustible Wall Clearances:			
Sides	1" (25mm)	Back	3" (76mm)
Entry Clearances: In (mm)			
Crated	44-1/2 (1130)	Uncrated	32-1/2 (826)

Notes:

- Standard electrical specifications include motor requirements.
- Single speed 3/4 HP, 1725 rpm 60Hz
- Optional 2-speed motor, 1140 and 1725 rpm, 60Hz.

Form# SCOES (06/22/12)