



Project Name: _____ AIA#: _____ Model #: _____

Location: _____ SIS#: _____ Item #: _____ Quantity: _____



4975N Premium Heavy-Duty Automatic Slicer

Protech™ Premium Model:

4975N Nine Speed Auto Slicer



Made in the U.S.A.

GLOBE FOOD EQUIPMENT COMPANY

Premium Heavy-Duty Automatic Slicer

4975N

**Certified by NSF International to go above and beyond standard performance!
NSF ANSI 8 2010 Standard**

Premium Construction

- 13" *PreciseEdge™* hardened steel alloy knife blade with Rockwell 60/62 hardness which maximizes tip-edge-holding ability
- Exclusive stainless steel construction, with superior corrosion resistance against acids found in fruit, meats and vegetables
- Best of the Best, *EZ-Glide™* table
- No-drip base with Marine edge redirects liquids to center of base away from controls and operator
- Precise slice-thickness adjustment, one-piece handle, gear driven and gasket-sealed
- Carriage angle: 45°, full gravity feed
- 2° angled drip groove on the slicer table directs the flow of liquids to the base
- 12" long chute with 3 lb. stainless steel end weight
- Powerful 1/2 HP, 7 amp continuous use motor
- High-performance gear knife drive
- Maintenance-free drive system
- Permanently attached knife ring guard with removable slice deflector

Food Zone Features

- Large stainless steel radii, open space base design for cleaning and simple dismantling of components
- Base has a Marine edge from 1/2" to 3/4" wide and indented areas with 3/16" deep radiused transition and 3/16" deep internal coved corners. Both are integral to the base's work surface

- Knife sharpening system is removable and BPA Free (no-bisphenol-A), immersible, and dishmachine-safe for cleaning and sanitizing
- Moisture proof, easy-to-clean direct contact start/stop touchpad controls
- Sealed splash zones for added sanitation and protection of electronics

Operator Full-featured Protections

- Home position start
- Table lockout- removal of the knife cover locks the slicer table so it cannot be opened. Additionally, the slicer table fully covers the knife edge during cleaning
- Automatic shut-off after 10 seconds
- Automatic return home - returns the chute to the home position when slicer is turned off
- No voltage release prevents inadvertent reactivation of slicer in the event of power or interlock interruption
- Knife cover interlock prevents slicer from operating without the knife cover
- Permanent knife blade ring guard, removable cover and deflector
- Touch pad start/stop controls and power indicator light
- Ergonomic low-profile design reduces operator fatigue
- Dual arm lift lever for cleaning and sanitizing under the slicer

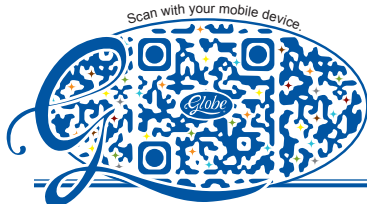

GLOBE FOOD EQUIPMENT COMPANY
2153 Dryden Rd., Dayton, OH 45439
Phone: 937-299-5493 Fax: 937-299-4147
800-347-5423
www.globeslicers.com

Approved By: _____

Date: _____



Premium Heavy-Duty Automatic Slicer

4975N

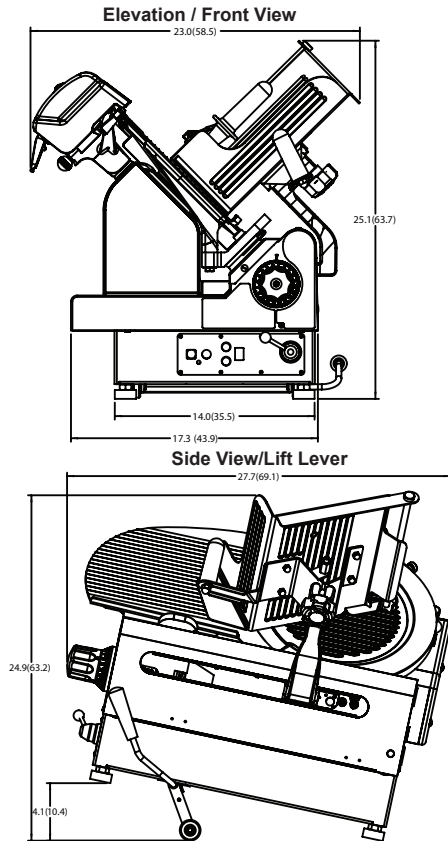

4975N

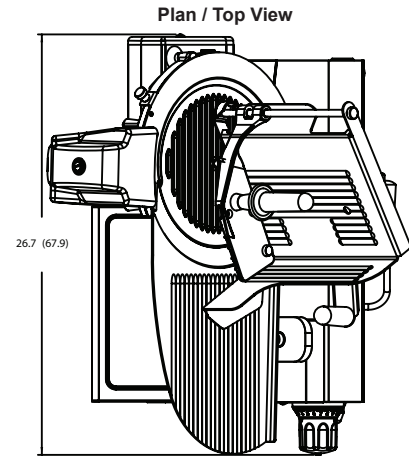
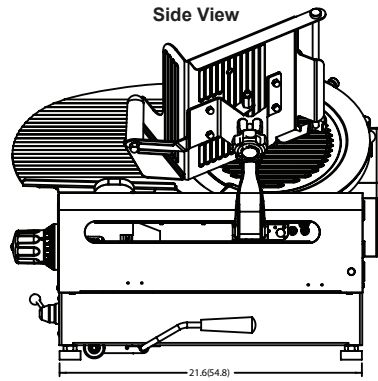

Note: Different chute options will change overall height

Drawings available through KCL. www.kclcad.com

Model	Elevation	Right	Plan	Back	BIM 3D	Revit
4975N						

SPECIFICATIONS

Model	Auto or Manual	Motor	Volts	Amps	Drive Type	Slicing Volume per Day	Cheese Slicing	Blade Diameter	Max Slice	Product Cutting Capacity	D (Diameter)	W (Width)	H (Height)
4975N	Both	1/2 HP	115-60-1	7	Gear	All Day		13" (33.02 cm)	1-1/4" (3.18 cm)	7.5" (19.50 cm)	11.6" (29.46 cm)	9" (22.86 cm)	

Cord & Plug: Attached 7 foot flexible 3-wire cord with molded plug fits a grounded receptacle. NEMA 5-15

FACTORY INSTALLED OPTIONS:

- Quick-Clean™ proprietary non-stick nickel-based coating (knife cover and slice table)
- Correctional package
- High moisture application package (includes 13" stainless steel knife)
- 15" long food chute
- 13" stainless steel knife

SLICER ENHANCEMENT ACCESSORIES:

- Stainless steel low food fence (12" L x 1 3/8" H)
- Stainless steel high food fence (12" L x 3" H)
- 7" D x 14" L Stainless steel vegetable hopper
- Clear plastic slicer cover (Tip: Recommended for preconstruction)
- Additional cleaning brush

WARRANTY:

- 15 years on the knife drive gears
- Two-years parts
- One-year labor

Warranty valid in North America. Contact factory for warranty in other countries

DIMENSIONS & SHIPPING INFORMATION

Freight Class 77.5

Cartons are reinforced for shipping. The weight and dimensions of this reinforced carton are included below, may vary from shipment to shipment and may include the weight from an attached skid.

Model	Foot Print	Overall Dimensions	Net Weight	Shipping Dimensions	Shipping Weight
4975N	14" D x 21.6" W (35.5 cm x 54.8 cm)	26.7" L x 23" W x 25.1" H (69.7 cm x 58.5 cm x 63.7 cm)	149 lbs. (67.5 kg)	28" L x 25" W x 34" H (71.1 cm x 63.5 cm x 86.4 cm)	181 lbs. (82 kg)



GLOBE FOOD EQUIPMENT COMPANY

www.globeslicers.com

2153 Dryden Rd.
Dayton, OH 45439
Phone: 937-299-5493
Phone: 800-347-5423
Fax: 937-299-4147