



Project Name: _____ AIA#: _____ Model #: _____

Location: _____ SIS#: _____ Item #: _____ Quantity: _____

Chefmate™ Gas Charbroilers SST Radiants



C24CB-SR

Models

- C24CB-SR - 24" Gas Charbroiler
- C36CB-SR - 36" Gas Charbroiler



GLOBE FOOD EQUIPMENT COMPANY

Chefmate™ Gas Charbroilers, SST Radiants C24CB-SR / C36CB-SR

Quality Construction

- Charbroiler with heavy-duty 10-gauge stainless steel radiant for maximum heat distribution
- Available in 24" and 36" widths
- Durable steel U-style burner provides heat control every 12" and flame every 6"
- Stainless steel construction and extended cool-to-touch front edge

Standard Features

- High performance 35,000 BTUs per burner
- Heavy-duty cast iron, reversible grates with 3 adjustable grilling positions
- Adjustable pilots with front access
- 4" H back and side splash protection against grease and spills
- Stainless steel legs with adjustable non-skid feet
- Cooktop lifts off completely for easy cleaning and servicing
- Unit ships Natural Gas with LP conversion kit included

Warranty

- One-year parts and labor

Standard Accessories

- Stainless Steel Full-Length Catch Tray
- LP Conversion Kit
- Regulator



GLOBE FOOD EQUIPMENT COMPANY
2153 Dryden Rd., Dayton, OH 45439
Phone: 937-299-5493 Fax: 937-299-4147
800-347-5423

www.globeslicers.com

Approved By: _____

Date: _____



Chefmate™ Gas Charbroilers, SST Radiants C24CB-SR / C36CB-SR

C24CB-SR

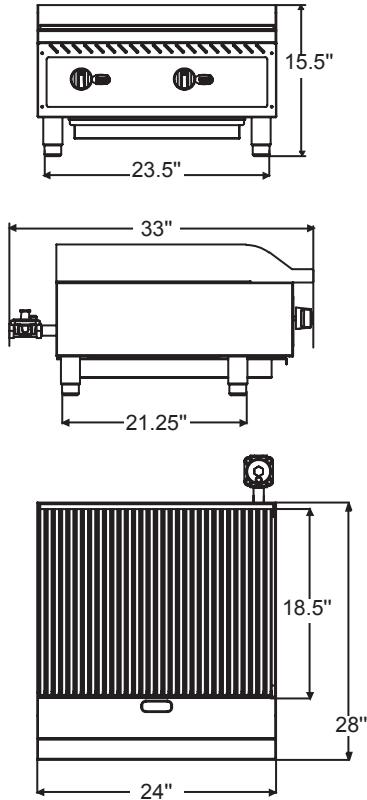

C36CB-SR

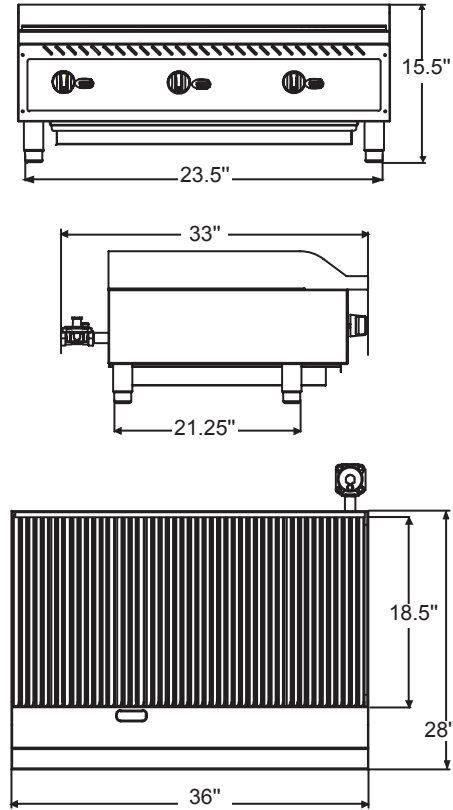

For Indoor Use Only

SPECIFICATIONS

GAS REQUIREMENTS:

- Natural Gas or Liquid Propane Gas main supply required.
- All units ship Natural Gas ready. Liquid Propane conversion kit is included for kitchens equipped with this gas type. Conversion of your unit from Natural Gas to LP must be completed by an authorized Globe servicer.
- 3/4" standard pipe size I.D. connection.
- 35,000 BTUs per burner. One pilot per burner.

Model	Cooking Area	Controls	Number of Burners	BTUs (per burner)	Total BTUs
C24CB-SR	18.5" D X 24" W	Manual	2	35,000	70,000
C36CB-SR	18.5" D X 36" W	Manual	3	35,000	105,000

STANDARD FEATURES:

- All stainless steel construction
- Cast iron cooking racks
- LP conversion kit
- Regulator
- Full-width catch tray
- 35,000 BTUs per burner
- One U-style burner provides flame every 6"
- Heavy-duty stainless steel radiants
- Adjustable pilots with front access

DIMENSIONS & SHIPPING INFORMATION

Freight Class 85

Carton reinforced for shipping. The weight and dimensions of reinforced carton are included below and may vary from shipment to shipment. **These items are shipped on a pallet.**

Model	Foot Print	Overall Dimensions	Net Weight	Shipping Dimensions	Shipping Weight
C24CB-SR	21.25" L x 23.5" W (54 cm x 60 cm)	33" L x 24" W x 15.5" H (84 cm x 61 cm x 33.7 cm)	110 lbs (50 kg)	34" L x 29" W x 19" H (87 cm x 73 cm x 49 cm)	150 lbs (68 kg)
C36CB-SR	21.25" L x 35.5" W (54 cm x 90 cm)	33" L x 36" W x 15.5" H (84 cm x 91 cm x 39.7 cm)	159 lbs (72 kg)	34" L x 41" W x 19" H (87 cm x 105 cm x 49 cm)	218 lbs (99 kg)



GLOBE FOOD EQUIPMENT COMPANY

www.globeslicers.com

2153 Dryden Rd.
Dayton, OH 45439
Phone: 937-299-5493
Phone: 800-347-5423
Fax: 937-299-4147