



Project Name: \_\_\_\_\_ AIA#: \_\_\_\_\_ Model #: \_\_\_\_\_

Location: \_\_\_\_\_ SIS#: \_\_\_\_\_ Item #: \_\_\_\_\_ Quantity: \_\_\_\_\_



# 10 Quart Countertop Mixer

*Built into each mixer is the quality  
of workmanship and design  
synonymous with Globe.*

### Model

- SP10 - 10 Quart Planetary Mixer



### Standard Features

- Powerful 1/3 HP custom built motor
- Three fixed speeds
- Gear-driven, high torque transmission
- Heat-treated hardened steel alloy gears and shafts
- Permanently lubricated transmission
- Thermal overload protection
- Front-mounted digital controls with 60 minute timer and last batch recall
- Rigid cast iron body
- NSF approved enamel gray paint
- Industry standard #12 attachment hub
- Safety interlocked bowl guard and bowl lift

- Non-slip rubber feet
- 6 foot cord and ground plug

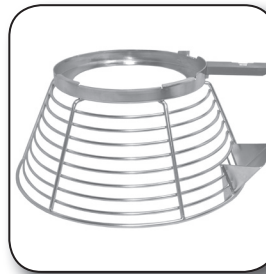

- High-quality stainless steel removable bowl guard with built-in ingredient chute
- Interlocking guard is easy to attach and remove for cleaning
- Dish machine safe

### Standard Accessories:

- 10 quart stainless steel bowl
- Flat beater (aluminum)
- Stainless steel wire whip
- Spiral dough hook (aluminum)

### Optional:

- Slicer/shredder/grater for #12 hub
- Meat grinder for #12 hub
- Flat beater (stainless steel)
- Spiral dough hook (stainless steel)
- Mixer table with undershelf
- Extended Warranty (More options on back)

### Warranty

- Two-year parts and one-year labor

GLOBE FOOD EQUIPMENT COMPANY

10 Quart Countertop Mixer

SP10



GLOBE FOOD EQUIPMENT COMPANY  
2153 Dryden Rd., Dayton, OH 45439  
Phone: 937-299-5493 Fax: 937-299-4147  
800-347-5423

[www.globeslicers.com](http://www.globeslicers.com)

Approved By: \_\_\_\_\_

Date: \_\_\_\_\_



# 10 Quart Countertop Mixer

# SP10

## SP10

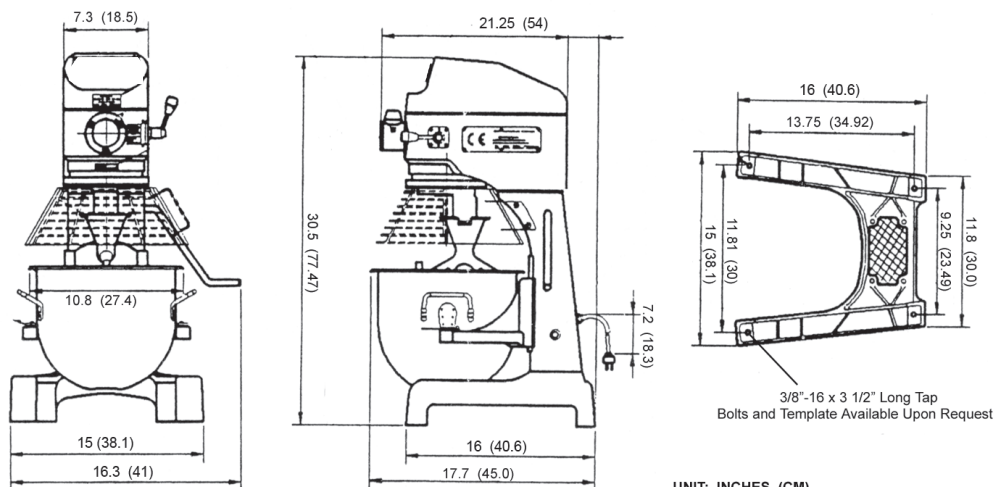

UNIT: INCHES (CM)

Drawings available through KCL. [www.kclcad.com](http://www.kclcad.com)

| Model | Elevation | Right | Plan | Back | BIM 3D | Revit |
|-------|-----------|-------|------|------|--------|-------|
| SP10  |           |       |      |      |        |       |

### SPECIFICATIONS

| Model | Motor  | Volts    | Amps | Transmission Type | Capacity    | Controls                               | Agitator Speeds (RPMs) |     |     | Attachment Speeds (RPMs) |     |     |
|-------|--------|----------|------|-------------------|-------------|----------------------------------------|------------------------|-----|-----|--------------------------|-----|-----|
|       |        |          |      |                   |             |                                        | 1st                    | 2nd | 3rd | 1st                      | 2nd | 3rd |
| SP10  | 1/3 HP | 115/60/1 | 5    | Gear              | 10 qt / 9 L | Front-mounted digital controls & timer | 104                    | 194 | 353 | 59                       | 110 | 201 |

**Cord & Plug:** Attached 6 foot flexible 3-wire cord with molded plug fits a grounded receptacle. NEMA 5-15P

#### STANDARD ACCESSORIES:

- 10 Quart #304 series stainless steel bowl
- Aluminum spiral dough hook and flat beater
- Stainless steel wire whip and bowl guard with built-in ingredient chute

#### OPTIONAL ATTACHMENTS & ACCESSORIES:

- **XXBOWL-10** Stainless steel bowl
- **XXBEAT-10** Alum. flat beater
- **XXBEAT-10SS** S/S flat beater
- **XXHOOK-10** Alum. dough hook
- **XXHOOK-10SS** S/S dough hook
- **XXWHIP-10** S/S wire whip
- **XXHDWHIP-10-4** Heavy-duty 4 mm S/S wire whip

• **XTable** S/S countertop mixer table with under shelf (30" W x 24" D x 24" H)

#### Chopper Plate Sizes Available:

- **CP02-12** 1/16" (2 mm)
- **CP04-12** 5/32" (4 mm)
- **CP05-12** 3/16" (5 mm)
- **CP06-12** 1/4" (6 mm)
- **CP08-12** 5/16" (8 mm)
- **CP10-12** 3/8" (10 mm)
- **CP12-12** 1/2" (12 mm)
- **CP14-12** 9/16" (14 mm)
- **CP16-12** 5/8" (16 mm)
- **CP18-12** 11/16" (18 mm)
- **CP00-12** Stuffing Plate
- **XST12** 1/2" stuffing tube (sheep)
- **XST34** 3/4" stuffing tube (hog)
- **XMCA-SS** Meat Grinder Assembly (Polished stainless steel cylinder, worm gear, ring, and s/s pan. Includes knife, 3/16" plate, and pusher.)

• **XXCK** Chopper knife for the XMCA-SS

• **XASP** Adjustable slicing plate (for vegetables only)

• **XVSGH** 9" Slicer/Shredder/Grater Housing Only (no plates included-must select from plates listed below)

• **XPH** Plate holder -\*only 1 required

#### Shredding Plates:

- **XSP332\*** 3/32" (2.3 mm)
- **XSP316\*** 3/16" (4.7 mm)
- **XSP14\*** 1/4" (6.3 mm)
- **XSP516\*** 5/16" (7.9 mm)
- **XSP12\*** 1/2" (12.7 mm)
- **XGP\*** Grating plate

#### FACTORY INSTALLED OPTION:

- **XXCORR10** Correctional package includes tamper resistant external fasteners.

#### EXTENDED WARRANTY

- **SP-XD1020** Extended warranty for the SP10 mixer. Coverage extends factory warranty to 2-years. Only available at time of purchase.

### DIMENSIONS & SHIPPING INFORMATION

Freight Class **85**

Cartons are reinforced for shipping. The weight and dimensions of this reinforced carton are included below and may vary from shipment to shipment. **This product ships on a pallet.**

| Model | Foot Print                       | Overall Dimensions                                   | Net Weight          | Shipping Dimensions                                | Shipping Weight      |
|-------|----------------------------------|------------------------------------------------------|---------------------|----------------------------------------------------|----------------------|
| SP10  | 16" D x 15" W<br>(41 cm x 38 cm) | 22" L x 16" W x 30.5" H<br>(56 cm x 41 cm x 77.5 cm) | 135 lbs.<br>(60 kg) | 40" L x 32" W x 42" H<br>(102 cm x 81 cm x 107 cm) | 245 lbs.<br>(111 kg) |



## GLOBE FOOD EQUIPMENT COMPANY

[www.globeslicers.com](http://www.globeslicers.com)

2153 Dryden Rd.  
Dayton, OH 45439  
Phone: 937-299-5493  
Phone: 800-347-5423  
Fax: 937-299-4147