

Project _____

Item # _____

Quantity _____



GLOBE FOOD EQUIPMENT COMPANY

25 Quart Mixer

SP25



SP25 25 Quart Mixer

Model

- SP25 - 25 Quart Mixer

Built into each mixer is the quality of workmanship and design synonymous with Globe.



Standard Features

- Powerful 3/4 HP custom built motor
- Three fixed speeds
- High torque transmission
- Heat-treated hardened steel alloy gears and shafts
- Permanently lubricated transmission
- Thermal overload protection
- Rigid cast iron body
- Removable stainless steel bowl guard with built in ingredient chute
- NSF approved enamel gray paint
- Front mounted controls
- 15 minute timer
- Industry standard #12 attachment hub
- Safety interlocked bowl guard and bowl lift
- Non-slip rubber feet
- 6 foot cord and ground plug

Standard Accessories

- 25 quart stainless steel bowl
- Flat beater (aluminum)
- Stainless steel wire whip
- Spiral dough hook (aluminum)

Optional Attachments/Accessories

- Slicer/shredder/grater for #12 hub
- Meat grinder for #12 hub
- 10 quart adapter kit
- Mixer table with undershelf

Standard Warranty

- Two-years parts and one-year labor

Featuring a Removable Bowl Guard

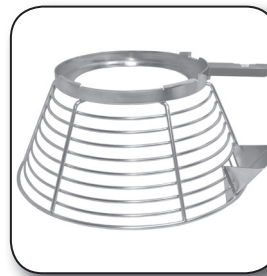

- High-quality stainless steel removable bowl guard
- Interlocking guard easy to attach and remove for easy cleaning
- Dish machine safe

Approved By: _____

Date: _____



GLOBE FOOD EQUIPMENT COMPANY

www.globeslicers.com

2153 Dryden Rd.
Dayton, OH 45439
Phone: 937-299-5493
Phone: 800-347-5423
Fax: 937-299-4147



25 Quart Mixer

SP25

Specifications

Motor: 3/4 HP, grease packed ball bearing, air cooled, 115/60/1, 11 amps. Thermal overload protection (automatic reset).

Finish: NSF approved enamel gray paint.

Capacity: 25 quart (24 liter) bowl.

Transmission: Fixed speed transmission is made of heat treated, hardened alloy, precision milled gears that operate the planetary action and provide high torque mixing power. The gears are packed in a long lasting grease, and all shafts are mounted in ball bearings.

Safety Interlocks: The bowl guard and bowl lift lever are interlocked. The mixer will automatically shut down when the guard is opened or the bowl is lowered.

Agitator Speeds (RPMs):

Low	101
Intermediate	185
High	355

Attachment Speeds (RPMs):

Low	57
Intermediate	105
High	202

Standard Equipment: Standard equipment includes a 25 quart #304 series stainless steel bowl, aluminum spiral dough hook, stainless steel wire whip, aluminum flat beater, removable stainless steel bowl guard with built in ingredient chute, 15 minute timer, and #12 attachment hub. A sturdy hand lever on the body column raises and lowers the bowl as well as locking in place at the top and bottom positions.

Cord: 6 ft. flexible three wire cord and ground plug. NEMA 5-15P

Dimensions:

Foot Print = 18.8" x 18.4"
 (47.8cm x 46.7cm)
 Overall Length = 21.9" (55.6cm)
 Overall Width = 22.5" (57.2cm)
 Overall Height = 35.9" (91.2cm)

Shipping Information:

Freight Class: 85
 Net Weight: 264 lbs. (120 kgs.)
 Shipping Weight: 325 lbs.(147.1 kgs.)
 Shipping Dimensions:
 32"W x 40"D x 49"H
 (81.3cm x 101.6cm x 124.5cm)
 Cartons are affixed to a skid (pallet). The weight and dimensions of this skid are included above and may vary from shipment to shipment.

Optional Accessories:

XXACC10-25 Adapter Kit (includes a 10 quart bowl, wire whip, dough hook, flat beater, and bowl adapter to adapt 25 quart mixer to a 10 quart capacity)

XTABLE Mixer Table with Undershef (stainless steel top with galvanized steel undershef and legs)
30"W x 24"D x 24"H
(76.2cm x 61cm x 61cm)

Optional Attachments:

XMCA-SS Meat Grinder Assembly (Polished stainless steel cylinder, worm gear, ring, and pan. Includes knife, 3/16" plate, stainless steel pan, and pusher.)

Chopper Plate Sizes Available:

CP02-12	1/16"	(2mm)
CP04-12	5/32"	(4mm)
CP05-12	3/16"	(5mm)
CP06-12	1/4"	(6mm)
CP08-12	5/16"	(8mm)
CP10-12	3/8"	(10mm)
CP12-12	1/2"	(12mm)
CP14-12	9/16"	(14mm)
CP16-12	5/8"	(16mm)
CP18-12	11/16"	(18mm)
CP00-12	Stuffing Plate	
XST12	1/2" stuffing tube (sheep)	
XST34	3/4" stuffing tube (hog)	

XVSGH 9" Slicer/Shredder/Grater Housing Only (no plates included- must select from plates below)

XASP Adjustable slicing plate
XPH Plate holder - *only 1 required

Shredding/Grating Plates:

XSP332*	3/32"	(2.3mm)
XSP316*	3/16"	(4.7mm)
XSP14*	1/4"	(6.3mm)
XSP516*	5/16"	(7.9mm)
XSP12*	1/2"	(12.7mm)
XGP*	Grating plate	

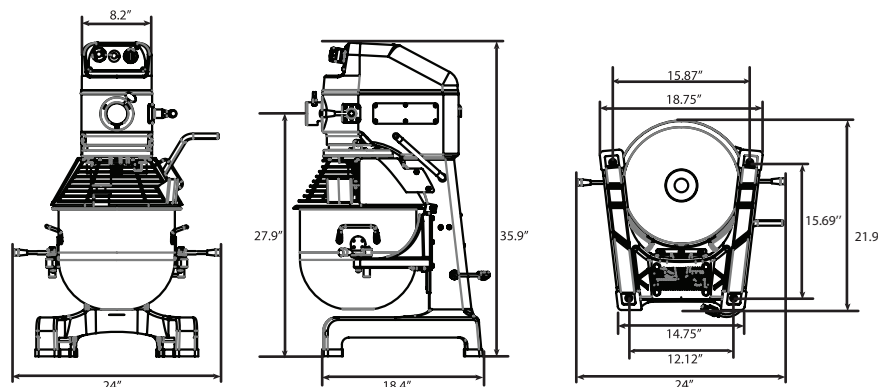

GLOBE FOOD EQUIPMENT COMPANY

www.globeslicers.com

2153 Dryden Rd.
 Dayton, OH 45439
 Phone: 937-299-5493
 Phone: 800-347-5423
 Fax: 937-299-4147

Specifications are subject to change without notice.

Printed In U.S.A. 02-2013