

Project: _____	AIA# _____
Item #: _____ Qty: _____	SIS# _____
Model #: _____	

Bottle Disintegration System

BDS



BDS



Intertek

4004503

Conforms to ANSI/UL STD 73
 Certified to CSA STD
 C22.2 No. 68

Standard Features

- Reduces volume of glass bottle waste by as much as 85%
- Disintegrates beer, wine, and liquor bottles up to 4" in diameter and 14" in height
- The 4-gallon bucket holds approximately 43 lbs when full and is accessible for emptying by opening the front door
- Compact design fits easily under the bar or in a service station
- It takes mere seconds to crush a bottle and is no louder than a standard blender
- Stainless steel interior and exterior resists corrosion and is easy to keep clean
- Includes safety interlock switches to ensure safe operation. The unit shuts down and a red indicator light is illuminated if the front access door is open, the bucket is not in place, or if the bucket is full.
- Multi-level baffle system on feed chute and gasket seal to maximize glass containment
- No empties means more stock space and a cleaner environment
- Green indicator light identifies when unit is running
- Easy operation - simply turn it on and push a bottle down the feed chute
- Includes locking casters so unit can be easily moved for cleaning
- Weighs 142 lbs. Shipping weight is 167 lbs.
- Additional buckets may be ordered under accessory part number 14000053

Specifications

Electrical

- 120V, Single phase, 60Hz, 9-foot grounded cord included
- Dedicated 15 amp circuit recommended
- Power requirements - 9.0 amps
- Also available for export with 220V/50Hz or 220V/60Hz electrical. Specify accessory number CE-BDS.

Capacity

- The 4-gallon bucket weighs approximately 43 pounds and holds approximately 4 cases of disintegrated long neck beer bottles when full

Materials

- 20 gauge stainless steel parts include: cabinet, covers
- 14 gauge stainless steel parts include: drum, shelf
- 1/4" steel plate: motor mount
- Hardened steel: crusher bar
- Structural pipe, SCH 40: bottle chute

Service Access:

- Top cover, front top panel, and door must remain accessible for service
- One-half inch of clearance above top is required for proper air flow

Glastender, Inc. • 5400 North Michigan Road • Saginaw, MI • 48604-9780 989.752.4275 • 800.748.0423 • Fax 989.752.4444 www.glastender.com	Approval/Notes:
Specifications subject to change without notice. For current specifications please visit our website.	

Bottle Disintegration System

Dimensional Information

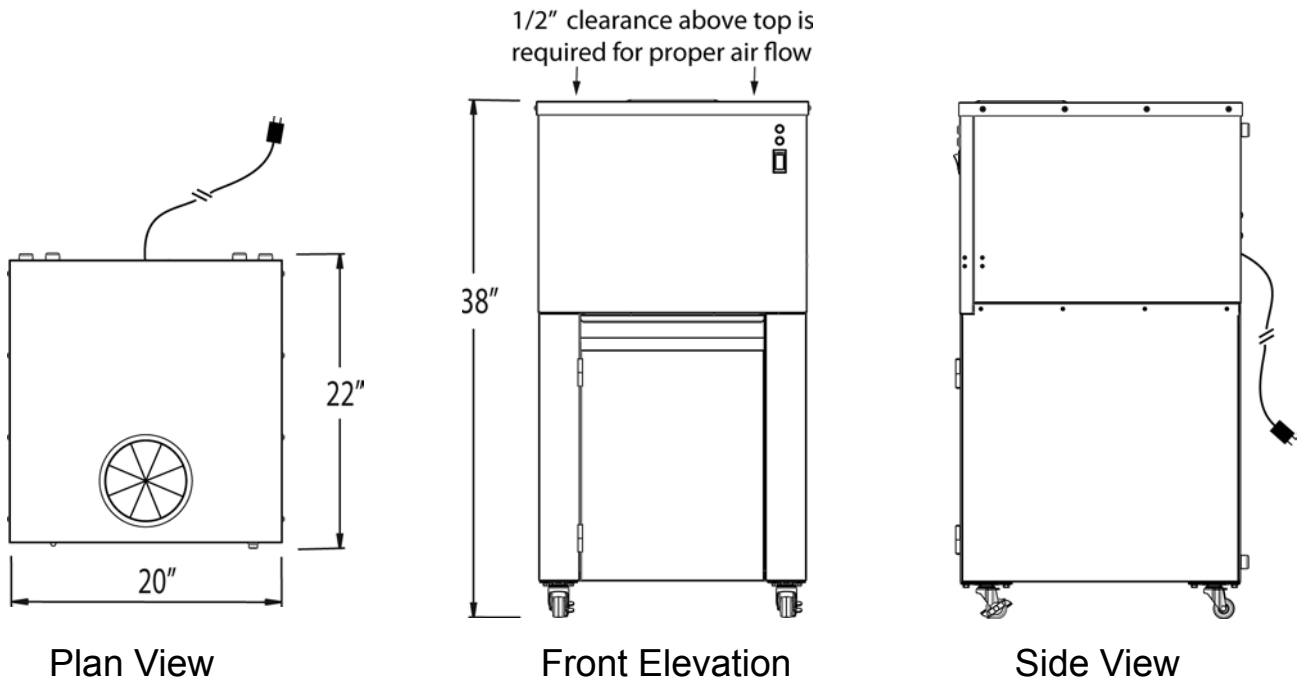

Accessory

The BDS includes a bucket. Additional buckets may be ordered under accessory part number 14000053.

