



Project: _____	AIA# _____
Item #: _____ Qty: _____	SIS# _____
Model #: _____	



C-IOS-18

Island Oasis Stand

C-IOS-18

Standard Features

- All stainless steel construction
- Adjustable thermoplastic bullet feet
- 1" deep drain pan work surface to capture excess moisture
- One-piece seamless top and backsplash featuring 1/4" radius corners for easy cleaning
- Lowered work surface with extended front
- Designed to keep the majority of the Island Oasis® (model #SB-3X) below the bar top with only the clear plastic ice tub visible above the bar top
- Chamfered front to eliminate "knee knockers"

Product Information

The Choice Island Oasis® Stand is designed for use with the model number SB-3X Island Oasis® machine. The 18" wide by 29" deep stand has a lowered draining work surface and extended front to allow the machine to be stored at a convenient and usable height. In most bar applications, the clear plastic ice container will be visible above the bar top.

To view cleaning and care instructions, please visit:
http://www.glastender.com/PDF/choice_ss_clean_care.pdf

Specifications

Drain

- 1-1/2" I.P.S. threaded drain will fit Dearborn part #8033 slipnut and part #W-573P washer

Legs

- 1-5/8" diameter, 16 gauge stainless steel
- Thermoplastic bullet feet

Materials

- 20 gauge stainless steel

Dimensional Information

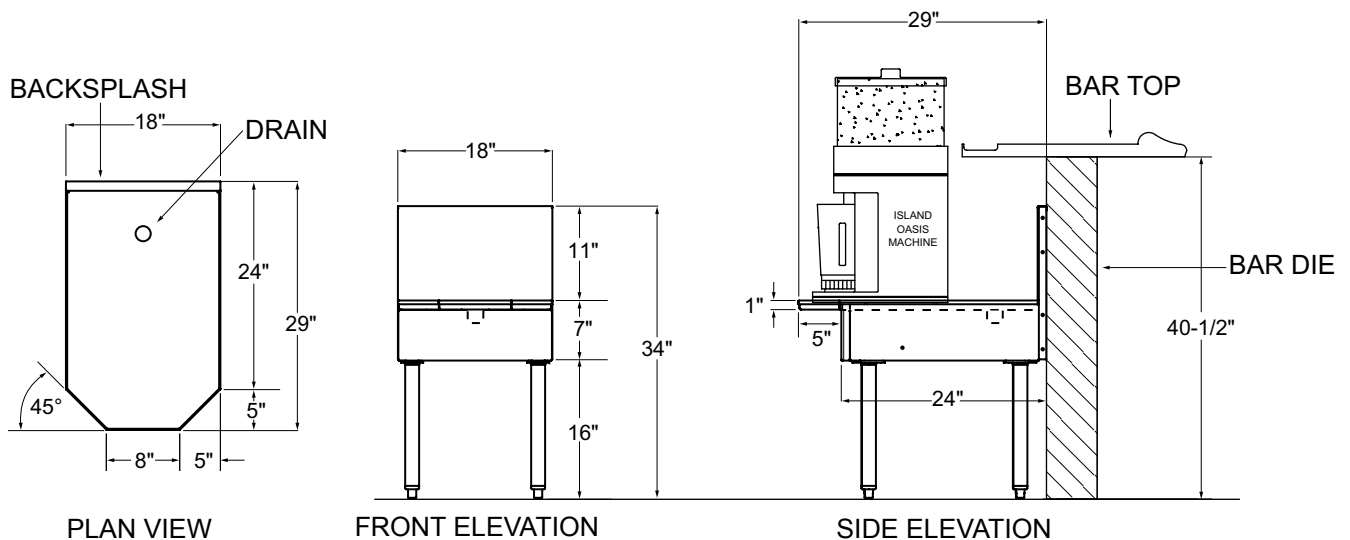

Glastender, Inc. • 5400 North Michigan Road • Saginaw, MI • 48604-9780
 989.752.4275 • 800.748.0423 • Fax 989.752.4444
www.glastender.com

Approval/Notes:

Specifications subject to change without notice. For current specifications please visit our website.