

Project: _____	AIA# _____
Item #: _____ Qty: _____	SIS# _____
Model #: _____	

Mobile Ice Cream Freezer

FRM-2



FRM-2

Standard Features

- All stainless steel exterior with 16 gauge galvanized steel exterior bottom.
- Completely integrated design - not just a cabinet with separate drop-in module
- All stainless steel interior liner with radius corners for easy cleaning
- One-piece, seamless top
- Includes four 3" casters, with two locking casters
- CFC free foamed-in-place insulation
- Six foot grounded cord and plug provided, exits at rear
- Designed to accommodate outlet behind unit and still sit flush against the wall
- Holds two 3-gallon containers



Intertek

Conforms to ANSI/UL STD 471
 Certified to CSA STD
 C22.2 No. 120

Specifications	Dimensional Information
-----------------------	--------------------------------

Capacity

- Two 3-gallon containers

Electrical

- 120V, 1 phase, 60 Hz, 4.2 full load amps
- Dedicated 15 amp circuit is recommended
- Includes 6 foot grounded cord and plug

Refrigeration

- Operating range -5°F (-20°C) to 10°F (-12°C)
- 1/5 HP, R404A refrigerant

Casters

- Four 3" heavy duty rubberized casters
- The two server side casters are locking

Materials

- 20 gauge stainless steel parts include: all components unless otherwise noted
- 16 gauge galvanized steel parts include: cabinet floor, condensing unit floor, and base channels

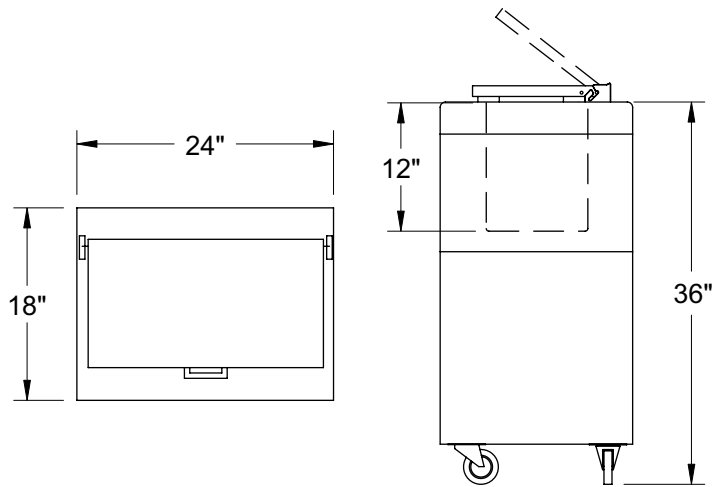

PLAN VIEW

SIDE ELEVATION

<p>Glastender, Inc. • 5400 North Michigan Road • Saginaw, MI • 48604-9780 989.752.4275 • 800.748.0423 • Fax 989.752.4444 www.glastender.com</p>	<p>Approval/Notes:</p>
Specifications subject to change without notice. For current specifications please visit our website.	