

| | |
|--------------------------|------------|
| Project: _____ | AIA# _____ |
| Item #: _____ Qty: _____ | SIS# _____ |
| Model #: _____ | |



Intertek

Conforms to ANSI/UL STD 471
 Certified to CSA STD
 C22.2 No. 120



KC24-NC-BS2(L)
 Shown with optional 2-faucet column tower for use with 1/6 barrel mini kegs*

24" Keg Cooler One Door Self-Contained

KC24-N - S ()

Base Height:
 1 = 1"
 C = 2" Casters
 6 = 6" Legs

Door Style:
 B = Black vinyl-clad
 S = Stainless

Door Hinge Location:
 L = Left or R = Right

Tower Style:
 1 = One Faucet
 2 = Two Faucets
 3 = Three Faucets

Top Style:
 S = Stainless

* **NOTE:** 1/6 barrel keg availability varies by region. Please consult your local distributor before ordering. Low profile keg taps, which only fit domestic style kegs, must be used for the 2nd and 3rd keg.

Standard Features

- Self-contained with six-foot grounded cord and plug
- Galvanized steel interior construction with stainless steel floor
- Stainless steel keg rack and 1/2" thick ABS plastic threshold scuff plate
- Foamed-in-place insulation
- Stainless steel finished top with recessed drain pan and lift-out perforated inserts
- Stainless steel 1-faucet column tower and optional two or three faucets for use with 1/6 kegs*
- Pre-plumbed plastic drain bottle for drain pan waste
- Black vinyl-clad steel exterior front and sides
- Chain included for securing optional CO₂ bottle
- Forced air evaporator with blower hose for cooling column tower

Specifications

Electrical

- 120V, 1 phase, 60 Hz, 3.6 full load amps
- Dedicated 15 amp circuit is required
- Includes a 6-foot grounded cord and plug which exits the bottom rear

Refrigeration

- 1/6 HP, R134a refrigerant

Operating Range

- 34°F (1°C) to 40°F (4°C)

Plumbing

- Automatic condensate evaporator. No drain connection required
- Includes a pre-plumbed plastic bottle for drain pan waste. A knock-out hole is provided if external draining is required.

Capacity

- One 1/4 barrel keg (7-3/4 gal.) or one 1/2 barrel keg (15-1/2 gal.) or three 1/6 barrel kegs (5 gal.)*

Materials

- 22 gauge, stainless steel parts include: interior floor, front of cabinet, and evaporator housing
- 22 gauge black vinyl-clad parts include: sides and standard door
- 22 gauge galvanized steel parts include: exterior sub-top and back and interior walls and ceiling
- 20 gauge stainless steel parts include: keg rack, finished top, drain pan inserts, and tower
- 16 gauge stainless steel parts include: legs
- 16 gauge galvanized steel parts include: base
- 16 gauge zinc plated CR steel parts include: leg sockets
- 12 gauge stainless steel parts include: hinges, hinge brackets, and lock brackets

Glastender, Inc. • 5400 North Michigan Road • Saginaw, MI • 48604-9780
 989.752.4275 • 800.748.0423 • Fax 989.752.4444
 www.glastender.com

Approval/Notes:

Specifications subject to change without notice. For current specifications please visit our website.

One Door 24" Self-Contained Keg Cooler

Dimensional Information

PLAN VIEW

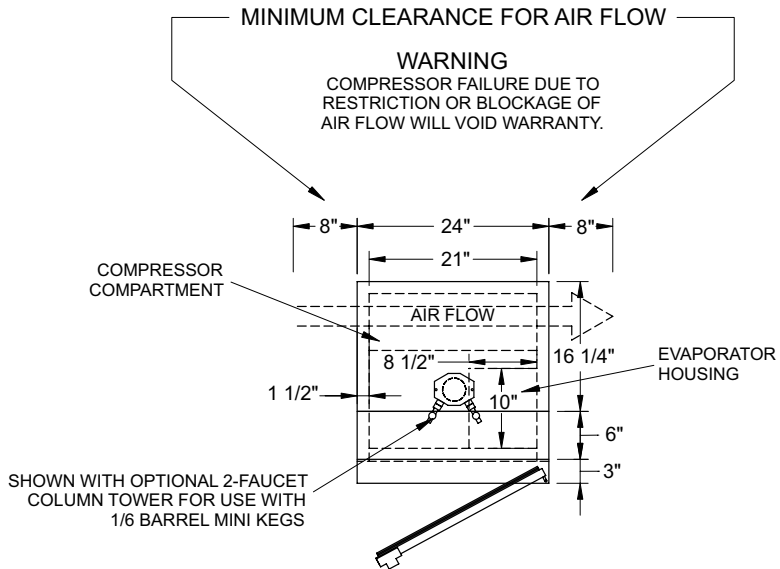

FRONT VIEW

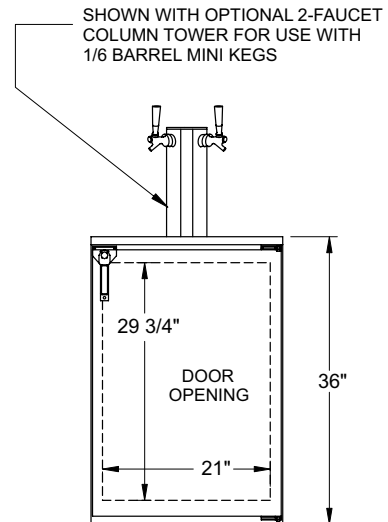

SIDE VIEWS

