



Project: _____	AIA# _____
Item #: _____ Qty: _____	SIS# _____
Model #: _____	

# LARGE WET WASTE STRAINER

LWS

## Standard Features

- Durable molded ABS plastic construction designed to withstand years of use
- Built-in handles for easy removal from sink
- Perforated bottom allows ice melt and liquid to pass through yet traps solid waste, preventing drain clogs
- Fits most standard bar sink bowls



LWS

### NO MORE CLOGGED SINK DRAINS!

The Glastender Large Wet Waste Strainer is the industry's only high capacity wet waste strainer designed specifically for your bar sink. The LWS allows you to dispose of wet waste into your sink, while straining out solid waste to prevent clogged drains.



LWS simply drops into a bar sink bowl

## Dimensional Information

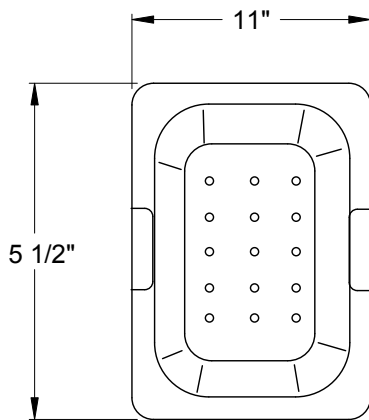

PLAN VIEW

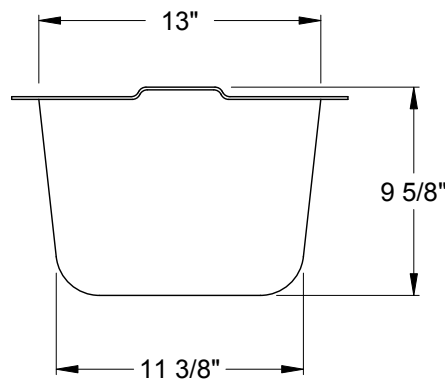

SIDE ELEVATION

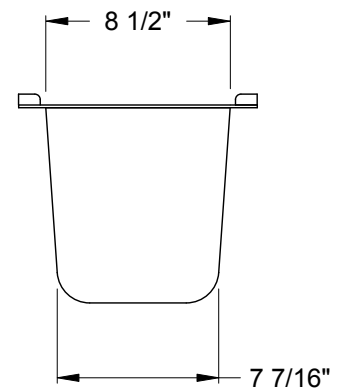

FRONT ELEVATION

<b>Glastender, Inc.</b> • 5400 North Michigan Road • Saginaw, MI • 48604-9780 989.752.4275 • 800.748.0423 • Fax 989.752.4444 <a href="http://www.glastender.com">www.glastender.com</a>	Approval/Notes:
Specifications subject to change without notice. For current specifications please visit our website.	