



SLD-24
(Liquor bottle rack
not included)



SLDC-24
(Liquor bottle rack
not included)



Project: _____	AIA# _____
Item #: _____ Qty: _____	SIS# _____
Model #: _____	

Slanted Liquor Displays

SLD-24, SLDC-24

Standard Features

- All stainless steel construction
- One-piece, seamless top and backsplash featuring 1/4" radius corners for easy cleaning
- For use with 20" x 20" liquor bottle racks for easy removal and storage of liquor bottles
- Angled work surface for easier access to rear bottles
- Mounting holes and cam-lock for securing to adjacent Glastender equipment

Additional Cabinet Model Features

- Locking cabinet base for storing liquor when not in use
- Four 2" casters with 2 locking caster on the front
- Removable floor with radius corners for easy cleaning
- Cabinet features smooth interior walls for easy cleaning and a finished appearance
- Integral door handle and door lock standard

Specifications

Legs

- 1-5/8" diameter, 16 gauge stainless steel
- Stainless steel bullet feet

Materials

- 20 gauge stainless steel parts include: all components unless otherwise noted
- 18 gauge stainless steel parts include: leg pads on SLDC-24

Glastender, Inc. • 5400 North Michigan Road • Saginaw, MI • 48604-9780 989.752.4275 • 800.748.0423 • Fax 989.752.4444 www.glastender.com	Approval/Notes:
Specifications subject to change without notice. For current specifications please visit our website.	

Slanted Liquor Display

Dimensional Information

SLD-24

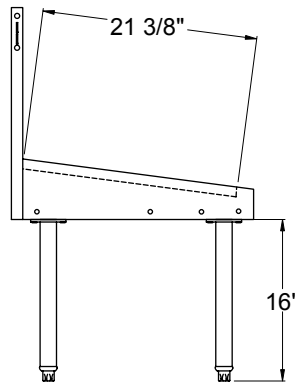
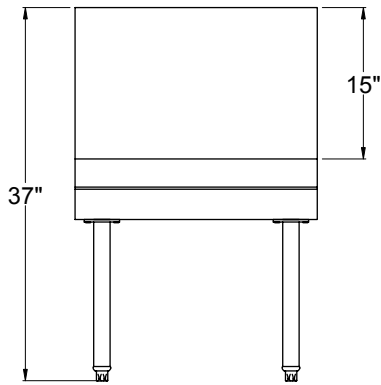
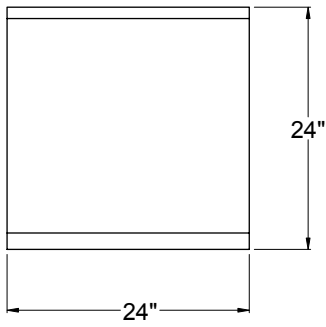

SLDC-24

