

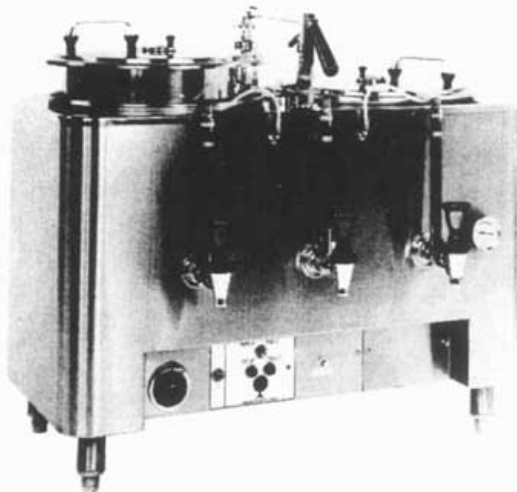

# Twin Space Saver Urn

SINCE 1883

**Dual Wall Insulated**  
**Electric or Steam Heat**  
**Models: 8103, 8106, 81010**



## Twin Automatic Coffee Urns

### FEATURES ONLY FROM AMERICAN

#### DUAL WALL FIBERGLASS INSULATION

Energy Saving. Minimum heat loss, saves on air conditioning costs. Saves cleaning labor, helps protect customer and operator from burn hazards.

#### SPACE SAVER DESIGN

In-base location of controls saves 18" to 24" of valuable counter space. All service handled from the front with drop down, easy access control panel.

#### TWO YEAR SERVICE WARRANTY, PARTS AND LABOR

Our quality guarantee.

#### EASY ADJUSTMENT OF SPRAYOVER RATE

Simple screwdriver adjustment. No awkward changing of parts. Two stage flow regulator system can be fine tuned to brew the finest quality coffee.

#### FOUR POSITION TEMPERATURE SELECTION ON THERMOSTAT.

In addition to brew and off there are two additional settings, "Nite Standby" and "Hold Standby."

#### THERMOSTAT "NITE STANDBY" SETTING

Saves energy and enables heat-up, ready to brew, in half normal time.

#### THERMOSTAT " HOLD SETTING"

Preserves the freshly brewed coffee by holding temperature at 180°F instead of the 200°F brew temperature.

#### QUICK CLEANING

Coffee compartment liner manufactured with a bright buff finish of the 304 grade stainless steel. Design allows for easy access and removal of plug-in, pop-out coffee gage connections. Plastic wing nuts make faucets easily removable without tools.

#### CLOSED CHAMBER BREWING

Prevents escape of coffee vapors. Brews with NSF approved cover on brew basket. Prevents steam/moisture loss out of the coffee liner. Saves energy with savings on air conditioning load. One 304 grade stainless steel brew basket with 25 filter papers included.

#### DRAIN ON BOTTOM OF URN



# Twin Space Saver Urn

SINCE 1883

## Twin Automatic Coffee Urns

### FEATURES THAT MAKE AMERICAN'S URNS SAFEST AND FASTEST TO SERVICE

#### LOW WATER CUTOFF SYSTEM

Protect against heater burnout, at start-up or in operation.

#### GREATEST SAFETY FOR OPERATION (OSHA)

All controls operate on 120 volts.

#### DRAIN VALVE IN BOTTOM WITH HOSE CONNECTION

#### STAINLESS STEEL BREW BASKET

With 25 filter papers.

#### OPTIONS AVAILABLE:

#### OPT.10 CORRECTIONAL/PRISON PACKAGE

#### FAST FILL DISPENSE OPTIONS

- Opt. 56 Jug fill Funnel and Chain
- Opt. 57 Gravity Jug Fill Hose Assembly
- Opt. 70 S1 High Speed Jug Fill Hose Assembly

#### MULTIPLE FAUCET OPTIONS

- Opt. DS-1 2C, 1W Back/Rear, No Gauges
- Opt. DS-2 1C, 1W Back/Rear, with Gauges
- Opt. DS-3L 2C, 1W Back/Rear, No Gauges with selecta-flow
- Opt. DS-8 2C, 1W Both Ends with Gage, No Operator Faucets
- Opt. DS-9 2C, 1W Both Ends, No Gage
- Opt. DS-10 1C, 1W Both Ends, No Gage
- Opt. DS-11 2C, 1W One End, No Gage
- Opt. DS-12 2C, 1W One End, No Gauge, with selecta-flow

#### DECORATIVE FINISHES AVAILABLE

- Opt. 94 SB Brass Body with Brass Trim
- Opt 94 SC Copper Body with Brass Trim
- Opt. 91 Vinyl Covering with Stainless Steel Trim, (specify color)
- Opt. 92 Vinyl Covering with Brass Trim, (specify color)

#### ROUGHING-IN DATA

Consult Factory for Current Roughing-in Drawing

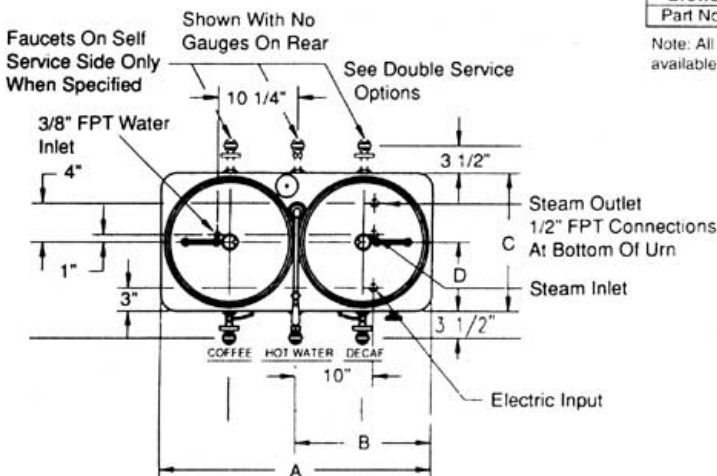

#### Dual Wall Insulated Models: 8103, 8106, 81010

Electric or Steam Heat

#### PRODUCTION ENGINEERING DATA

Model Number	8103	8106	81010			
Coffee Capacity Each Liner	3 Gallon	6 Gallon	10 Gallon			
Actual Brew Time Per Liner	6 Minute	9 Minute	14 Minute			
Brews Per Hour	9	6	4			
Gallons Per Hour	27	36	42			
Number of 5 oz. Cups Per Hour	675	900	1050			
Maximum Steam Demand Lbs. Per Hour	50	70	70			
Heater Size — KW	12 KW	11.5 KW	15 KW			
Heater Voltage	240V	208V	240V	208V	240V	208V
Amperes Drawn — 1Ph	50	54	63	72	63	72
Amperes Drawn — 3Ph	29	31	36	42	36	42

For 480-3Ph supply—divide amperes for 240V-3Ph by 2.

#### DESIGN SPECIFICATIONS (Fill in the blanks)

Coffee urn, fully automatic twin \_\_\_\_\_ gallons in coffee liner. Fresh water brewing using heat exchange system. Electric/steam service

All controls to be located in recessed base of urn and to operate on 120V. All AISI 304, 18 – 8 stainless steel construction. To include: positive low water cutoff system, automatic refill, automatic air agitation with plug-in type top coffee gage fittings, bypass on spray arm, variable sprayover rate, digital timer, electropolished liners and one all stainless steel brew basket for paper filters. Two year parts and labor warranty included. U.L. listed, NSF approved.

Model Number	A	B	C	Overall Height	Work Height
8103	31 1/2"	7 3/4"	16 1/4"	27 1/2"	22"
8106	35"	8 5/8"	17 3/4"	33 1/2"	28"
81010	35"	8 5/8"	17 3/4"	37"	30"

#### Brew Basket Selection Chart

Brews	3 Gallon	6 Gallon	10 Gallon	1/2 Batch on 3 Gallon	1/2 Batch on 6 Gallon	1/2 Batch on 10 Gallon
Part No.	BB3	BB6	BB610	BB3-1.5	BB6-3	BB610-6

Note: All SS Permanent Filter Brew Basket with SS woven wire cloth bottom is available. Filter paper is available from our stock. See price list.

#### ELECTRIC SERVICES AVAILABLE

Note: A ground wire must be provided in addition to the wire service shown

#### Neutral Wire Required

- 120/208V—single phase-3 wire
- 120/208V—three phase-4 wire
- 120/240V—single phase-3 wire

#### We Supply Control Transformer For:

- 208V—single phase-2wire
- 208V—three phase-3 wire
- 240V—single phase-2 wire
- 240V—three phase-3 wire
- 480V— three phase-3 wire — Extra Cost

All services include terminal block connection.

#### STEAM HEAT

Specify Operating Steam Pressure. Standards is 10 to 25 PSI Gauge.  
 1/2" FPT inlet and outlet. Requires plug-in of 3 wire cord to 120 volt AC outlet.  
 Steam trap to be supplied by others.



GRINDMASTER CRATHCO SYSTEMS, INC.  
"Global Customer Satisfaction"



Grindmaster Crathco Systems, Inc. • P.O. Box 35020 • Louisville, Kentucky 40232 USA • Phone (502) 425-4776 • Fax (502) 425-4664