

Table Top Kettles models TS/9 and Optional Drain Cart

Description

Stand shall be a Groen Size ____ (specify size 1 - 5) Model TS/9 stainless steel open leg support stand.

Kettle Stand Construction

Stand shall be manufactured from type 304 stainless steel with heavy duty 1 1/2" square tubing open leg frame, with 18" high, heavy gauge deck for ergonomic equipment mounting. Stand legs provided with 1" adjustable bullet feet.

Drain Cart Construction

TS/9S Models include a separate drain cart designed to stow under the kettle support stand and pull out for easy product transfers into steamer pans, stock pots or buckets, plus the safe and easy draining of cleaning water. Drain cart shall include a large 6" deep basin with high volume drain to a fixed lower drain pan. Rear leg casters and front leg glides provide easy movement and stability. A removable front hinged splash shield serves as a drain basin and work surface.

Finish

All stand surfaces shall be polished to a uniform No. 3 finish ensuring maximum ease in cleaning and maintaining brilliant appearance.

Sanitation

Kettle stand and drain cart stand shall be designed and constructed to meet known health department and sanitation codes and be NSF listed.

Installation

Model TS/9S stands with separate drain cart have a 1 1/2" drain connection for routing waste water to a nearby floor sink or waste water drain.

Options/Accessories

- Caster kit (2 locking and 2 non-locking)
- Stand mating bracket kit (bolt 2 TS/9s together)
- Drain installation kit (drain cart only)
- Flanged foot kit (4 each)

Origin of Manufacture

Support stand shall be designed and manufactured in the United States.

Stand Order Guide

Use this table when ordering a stand for table top equipment.

For Equipment		Order Stand No.
Model	Size	Stand Only
TDB/6-10	10 Qt.	TS/9-1
TDB or TDBC	20 or 40 Qt.	TS/9-2
TDH or TDHC	20 or 40 Qt.	TS/9-3
TD/FPC	10 Gal.	TS/9-4
TDB, TA/2	20 or 40 Qt.	TS/9-5

Model TDB-20 quart kettle mounted on Model TS/9-2 Stand with optional drain cart



Handy drain cart pulls out to assist in product transfer and cleanup



Removable splash shield hinges open to reveal 6" deep drain basin.



Sink will accept up to 6" deep steamer pans, 20 quart stock pot or colander for draining pasta.



Splash shield/cover when closed provides work surface for smaller pans, containers or bowls.

Stainless Steel Support Stands

For Table Top Self-Contained Kettles

Short Form

Groen Size ____ (specify 1 - 5) Model TS/9 stainless steel heavy duty open leg support stand. Kettle stand to have 1 1/2" square tube frame design; 18" high top for ergonomic equipment work height; and adjustable bullet feet. Separate drain cart (when specified) shall have large capacity 6" deep basin with rear drain, removable combination splash shield and cover, with rear casters and front leg glides for easy movement and stability. NSF listed. Made in U.S.A.

Applications

Provide proper operator work height

Assist in product transfer & cleanup

Provide access to remote floor drain

TABLE OF DIMENSIONS

MODEL	TS/9-1		TS/9-2		TS/9-3		TS/9-4		TS/9-5	
	INCHES	MM	INCHES	MM	INCHES	MM	INCHES	MM	INCHES	MM
DIM A	28	711	28	711	37 3/4	959	37 3/4	959	41 1/2	1054
B	21 1/2	546	28	711	28	711	28 1/4	718	27 1/2	699
C	10 3/4	273	18 1/16	459	18 1/16	459	17 5/8	448	17	432

STAND ORDER GUIDE		ORDER STAND NO.	
FOR EQUIPMENT	MODEL	STAND ONLY	STAND w/ DRAIN CART
TDB/6		10 QT. TS/9-1	TS/95-1
TDB OR TDHC		20 QT. TS/9-2	TS/95-2
TDB OR TDHC		40 QT. TS/9-2	TS/95-2
TDH OR TDHC		20 QT. TS/9-3	TS/95-3
TDH OR TDHC		40 QT. TS/9-3	TS/95-3
TD/FFC		10 GAL. TS/9-4	TS/95-4
TDB/TA/2		20 QT. TS/9-5	TS/95-5
TDB/TA/2		40 QT. TS/9-5	TS/95-5

NOTE: HOLE PATTERN WILL CHANGE PER MODEL SPECIFICATIONS

5/8 (1/16) KETTLE MOUNTING HOLES

PULL-OUT DRAIN BASIN (STOWED)

PULL-OUT DRAIN BASIN (IN-POSITION)

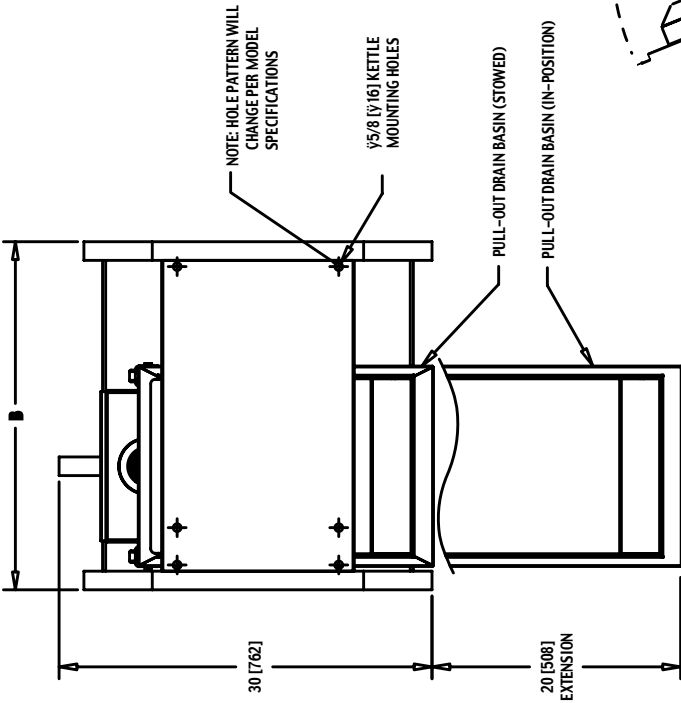

TOP VIEW

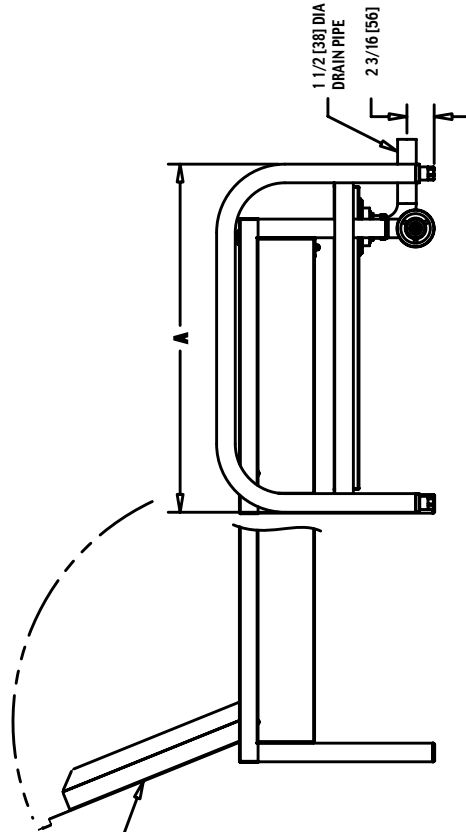

RIGHT SIDE VIEW

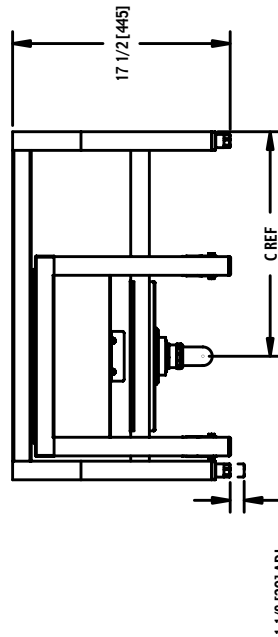

FRONT VIEW

