



# ECLIPSE BRAISING PANS

## MODEL BPM-15G

Braising pan shall be a Groen Eclipse™ Ergonomic Tilting Braising Pan BPM-15G, gas-heated, manual tilting braising pan with 8” deep pan on a round tubular leg stand.

**CONSTRUCTION:** The pan body shall be of type 304 stainless steel, solid one-piece welded heavy-duty construction, with 8” pan depth. All exposed surfaces shall be of stainless steel. The cooking surface is a heavy 5/8” thick stainless steel clad plate with specially designed welded heat transfer fins, heated by the gas burner/combustion chamber. This combination delivers more uniform heat transfer over the entire cooking surface. The heavy plate prevents warping or distortion. (SEE OPERATOR’S MANUAL FOR PROPER WARM UP SETTINGS). Controls and tilt mechanism are mounted in a stainless steel housing at the right side of the pan body. Braising pan shall come standard with a mounting bracket for either right-side, left- side or rear faucet mounting. Etch marks in both gallons and liters shall be included.

**FINISH:** Interior of braising pan shall be polished to a 100 emery grit finish. Exterior of braising pan shall be finished to a #3 finish, ensuring maximum ease in cleaning and maintaining appearance.

**C.S.A. DESIGN CERTIFICATION:** Braising pan shall be design-certified by CSA International (formerly AGA) for use with Natural Gas or LP Gas.

**SANITATION AND NSF LISTING:** Braising pan shall be designed and constructed to be NSF- listed, meeting all known health department and sanitation codes. True round leg tubular design and 3” radius pan interiors make cleaning easier.

**MANUAL TILT:** The braising pan shall have a smooth-action, quick-tilting body with manual crank tilt mechanism, which provides precise control during pouring of pan contents for easy operation. Pan body shall tilt past vertical to assist in cleaning.

**VENTED COVER:** A heavy-gauge, fully-adjustable one-piece cover is standard with torsion bar type counterbalance designed to maintain the selected cover position. A vent is provided in the cover top to regulate condensate buildup and a rear condensate drip shield is located under the cover to prevent condensate from dripping on floor when cover is opened.

**CONTROLS:** Operating controls include console-mounted ON power switch, ON power indicator light, HEAT indicator light; plus right-side, rear-mounted thermostat control box.

**PERFORMANCE FEATURES:** Braising pan shall be equipped with controls that allow operation at 7 degree angle to facilitate griddling. Braising pan shall be thermostatically-controlled for automatic shut- off when desired temperature is reached and automatic power ON when temperature falls below desired setting. Model BPM-15G has a firing rate of 65,000 BTU/hr. Electronic intermittent pilot ignition system is standard. Braising pans have high limit thermostat as a safety feature.

**INSTALLATION:** Unit requires 1/2” NPT gas connection. Requires one 120 Volt, single-phase, 60 HZ, 5 AMP supply.

**ORIGIN OF MANUFACTURE:** Designed and manufactured in the United States.

PROJECT NAME:

LOCATION:

ITEM NO:

QTY:

MODEL NO:

AIA NO:

SIS NO:

**SHORT FORM:** 15 Gallon, stainless steel, manual tilting, braising pan, round tubular leg, gas-heated.



### OPTIONS/ACCESSORIES:

- Braising pan with standing pilot
- Single pantry water fill faucet
- Double pantry water fill faucet
- 2” tangent drawoff valve (option: must be ordered with unit)
- Gas quick disconnect
- Flanged feet
- Strainer for tangent draw-off valve
- Pouring lip strainer
- Steamer pan inserts
- Single or double pantry faucet with spray hose assembly (48” or 60”)
- Casters



P/N 162623 REV B

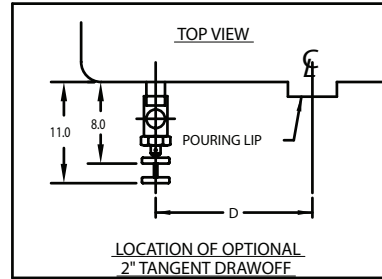
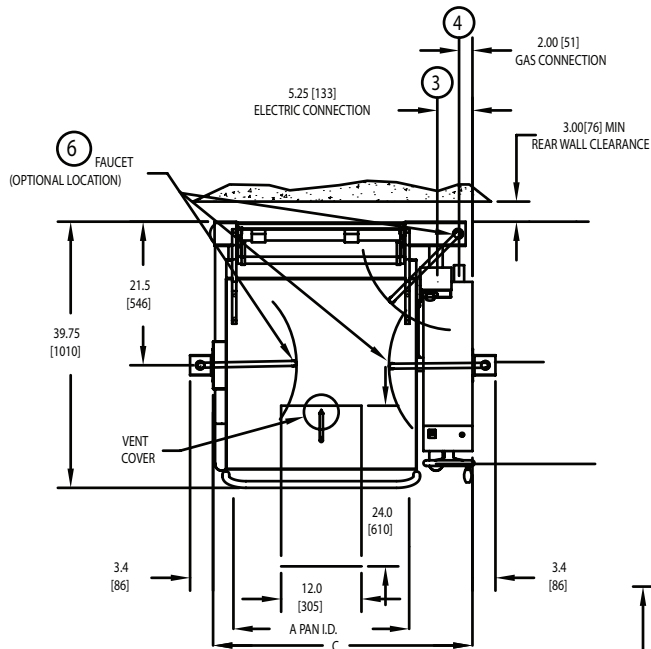

NOTES:

1. DIMENSIONS IN BRACKETS [ ] ARE MM.
2. CASTERS OR FLANGED FEET AVAILABLE AT AN EXTRA COST.
3. ELECTRICAL CONNECTION: 0.875" DIA. (22) HOLE 120V, 1 PH, 60 HZ, 5 AMPS.
4. GAS CONNECTION: 1/2" NPT.
5. ELECTRIC POWER NOT REQUIRED ON OPTIONAL STANDING PILOT MODELS (BPM-15GS).
6. FAUCET BRACKET MAY BE INSTALLED ON LEFT OR RIGHT SIDE.
7. THE SIZE AND LOCATION OF DRAIN TROUGH ARE FOR REFERENCE ONLY. USER SHOULD VERIFY SAFE OPERATION BASED ON FLOOR SLOPES, PLACEMENT OF UNIT OVER TROUGH, PRODUCT TO BE POURED, AND RELATED VARIABLES.

TOP VIEW

FRONT VIEW

RIGHT SIDE VIEW

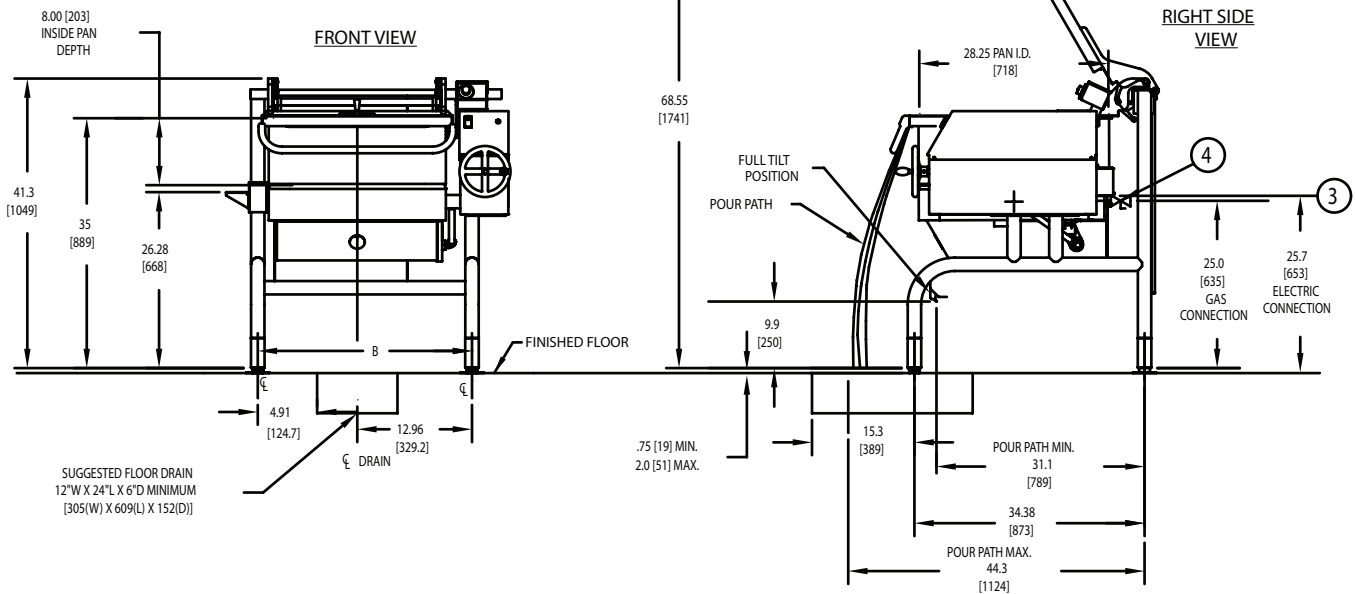

PERFORMANCE DATA	
MODEL	BPM-15G
FIRING RATE BTU/HR	65,000
CAPACITY	GALLONS 15
	LITERS 57

GAS FEED RATE: INCHES WATER COLUMN -RECOMMENDED INCOMING-	
NATURAL GAS	4.5" W.C. MIN. 14" W.C. MAX.
PROPANE GAS	11" W.C. MIN. 14" W.C. MAX.

TABLE OF DIMENSIONS			
MODEL	BPM-15G		
DIMS.	INCH	MM	
A	18.13	460.5	
B	23.88	606.6	
C	30.47	773.9	
D	3.5	88.90	