

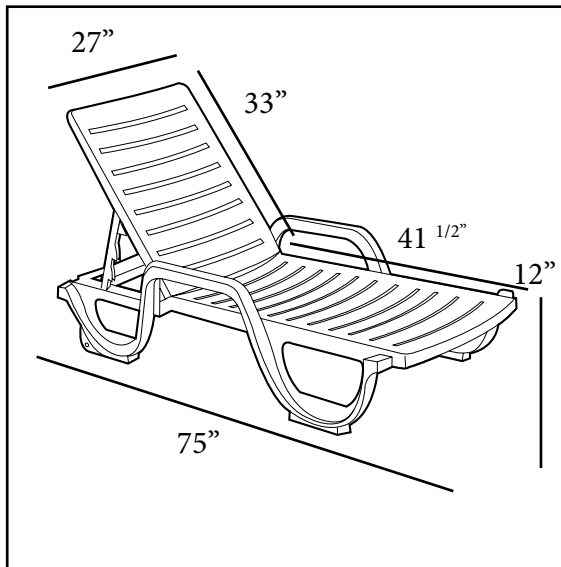

*Special Packaging!*

# Bahia Stacking Adjustable Chaise

Passes ASTM F 1988-99 Class B performance standard for commercial outdoor lounging



**Features & Benefits** **Warranty: 3 Yrs.**

- Specifically made for commercial use.
- Twice the resistance to U.V. degradation than the ordinary market chaise.
- Reinforced slats and frame for extra support.
- Rated to 300 pounds for resistance to breakage under static load.
- Recessed roll-away wheels for easy mobility and quick storage.
- Stackable; easy to store.
- Built-in safety guard prevents finger injuries caused by accidental fall of the adjustable back.
- Longer sleigh glides to prevent accidental front tilt.
- Rounded edges and 4-position adjustable back.
- Impervious to salt water, chlorine and most common stains.
- A true contract chaise for the professional.

<b>Product Specifications</b>						
Product Description	Reference Number	Color	UPC Code 014306	Weight Each (lbs.)	Master Pack	Master Pack Volume (cu. ft.)
Bahia Stacking Adjustable Chaise	44031004	White	702193	29.17	6	51.90
	44031066	Sandstone	610764			
<i>Special Packaging (Backrest is RTA)</i>	44031104	White	139821	27.50	18	93.38
	44031166	Sandstone	107622			
	US031004	White	702193	30.00	2	19.49
	US031066	Sandstone	610764			