



Flav-R-Savor® CONVECTED AIR, CURVED FRONT DISPLAY CASE

Models FSCD-2PD, FSCDH-2PD

Whether you're looking for a heated display unit for meals to go, or an added hot food station, Hatco's Flav-R-Savor® Convected Air Curved Display Case gives you all the features you desire. It's sleek design, curved glass front and lighting showcases food from all angles while using adjustable convected hot air to hold your products at peak serving temperature, 140° - 200°F (60° - 93°C). For more flexibility, consider the FSCDH-2PD model which adds humidified air to help hold food longer without sacrificing product moisture quality. Wrapped or unwrapped, on platters or in hotel pans, the FSCD-2PD or FSCDH-2PD showcases your products perfectly.

Our Swanstone®** base, perforated upper shelf, and our Flav-R-Savor heating technology puts the focus on your product, while Hatco's merchandisers hold your food safely at proper serving temperatures. Seven *Designer* color options blend the units with your decor: a perfect addition to front of the house service areas while providing an eye catching display case that is durable, reliable, and most of all, easy to clean with it's flip down curved front glass.

FLEXIBILITY

Available with or without humidity. These units come standard with a 3-sided skirt and base sign holder. The humidity unit has a 7-quart (6.63-liter) capacity water chamber.

QUALITY

The following features assure the finest performance for years to come:

- Hatco's signature convected air technology provides maximum holding times and peak serving temperatures
- Perforated stainless steel shelf enhances air movement over food products
- Focused lighting to enhance and merchandise your food products
- Hinged, tempered front glass panel tilts forward for easy cleaning.
- Easy to read, digitally controlled temperature and humidity (FSCDH-2PD model only) readouts for precise control
- Rear French doors for easy access
- Our integrated sign holder is there to help promote your product offerings (33.25"W x 6.125"H [845 W x 156 mm]) (sign not included) Recommended sign dimension: 33.125"W x 6"H (841 W x 152 H mm)
- Optional glass shelf available
- Available in seven *Designer* Colors, with *Designer* Black as standard (non-standard colors are non-returnable)
- Night Sky Swanstone®** panel on bottom shelf is standard, optional Gray Granite, Bermuda Sand, or Sawgrass (non-standard colors are non-returnable)

* Simulated Stone (approved for food contact)

METAL SHEATHED AIR HEATING ELEMENTS GUARANTEED AGAINST BURNOUT AND BREAKAGE FOR TWO YEARS.

Equipment
On Signage Program
Hatcographics.com

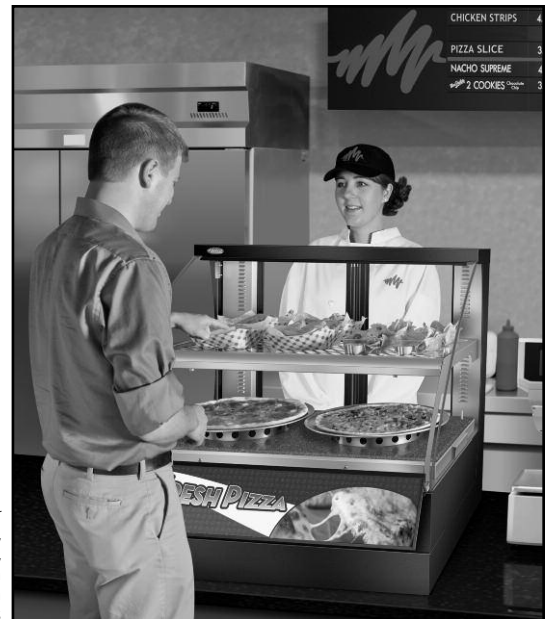

FSCDH-2PD in standard *Designer* Black, sign holder (sign not included), 3-sided skirt, perforated upper shelf, and Swanstone Night Sky base, with accessory circular perforated riser in stainless steel and food pans



FSCDH-2PD in standard *Designer* Black, sign holder (sign not included), 3-sided skirt, perforated upper shelf, and Swanstone Night Sky base, with accessory circular perforated riser in stainless steel

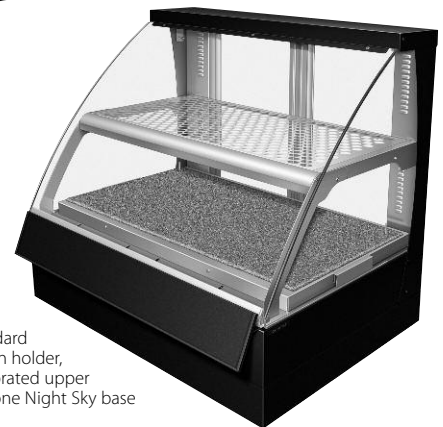

FSCD-2PD in standard *Designer* Black, sign holder, 3-sided skirt, perforated upper shelf, and Swanstone Night Sky base

Usable Heated Shelf Space – Upper32"W x 16"D.
– Lower32 1/8"W x 18"D.



HATCO CORPORATION P.O. Box 340500 Milwaukee, WI 53234-0500 U.S.A.
(800) 558-0607 • (414) 671-6350 • Fax (800) 543-7521 • Int'l. Fax: (414) 671-3976
www.hatcocorp.com • E-mail: equipsales@hatcocorp.com

Form No. FSCD Spec Sheet

Printed in U.S.A.
August 2012



Flav-R-Savor[®] CONVECTED AIR, CURVED FRONT DISPLAY CASE

Models FSCD-2PD, FSCDH-2PD

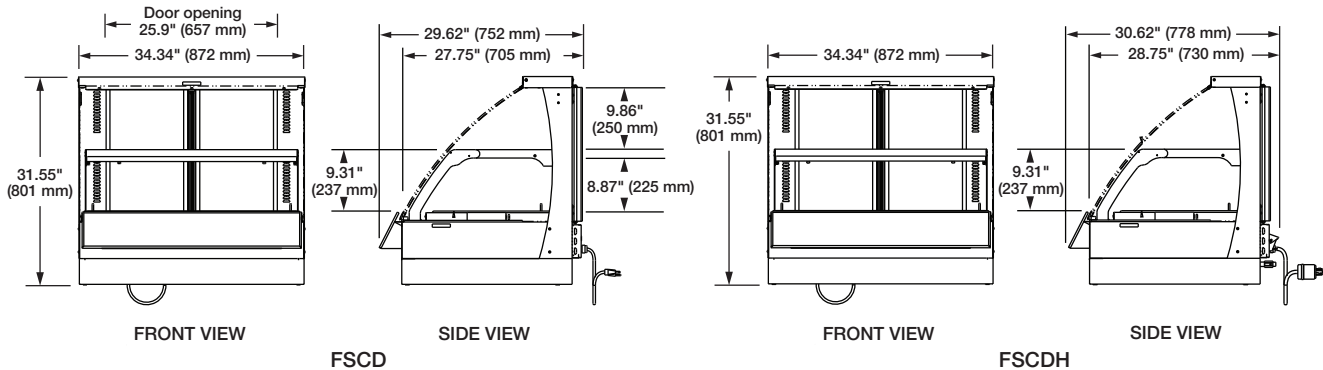

SPECIFICATIONS

Non Humidified

Model	Watts	Voltage	Shipping Weight
FSCD-2PD	1800	120	184 lbs. (84 kg)

Humidified

Model	Watts	Voltage	Shipping Weight
FSCDH-2PD	2805	120/208	190 lbs. (86 kg)
FSCDH-2PD	2805	120/240	190 lbs. (86 kg)

DIMENSIONS

FSCD-2PD:

34.34"W x 29.62"D x 31.55"H w/legs (872 x 752 x 801 mm).

FSCDH-2PD:

34.34"W x 30.62"D x 31.55"H w/legs (872 x 778 x 801 mm).

Usable Heated Shelf Space - Upper29.92"W x 15.5"D (765 x 393 mm)
- Lower.....32.12"W x 18"D (815 x 457 mm)

Water Capacity: 7 quarts (6.63 liters).

VOLTAGE

FSCD-2PD:

120, single phase, 15 Amps, NEMA 5-20P

FSCDH-2PD:

120/208-240V, single phase, 13.3 Amps, NEMA L14-20P

CORD LOCATION

Control side at right base corner.

PLUG CONFIGURATIONS

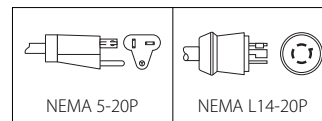

OPTIONS (NOT FOR RETROFIT)

- Designer Colors: Warm Red, Black, Gray Granite, White Granite, Navy Blue, Hunter Green, Antique Copper, non-standard colors are non-returnable
- Heated Stone Colors: Gray Granite, Bermuda Sand, Night Sky (standard), Sawgrass
- Valve relocation (Humidified model only)
- Glass center shelf (in lieu of perforated stainless steel shelf)

ACCESSORIES

- 10"D x 1.25"H (254 D x 32 H mm) circular perforated riser in stainless steel

PRODUCT SPECS

Convected, Curved Front Display Case

The Convected Air, Curved Front Display Case Flav-R-Savor[®] Model ... as manufactured by the Hatco Corporation, Milwaukee, WI 53234 U.S.A.

The Display Case shall be rated at ... watts, ... volts and be ... inches (millimeters) in overall width. Thermostatically-controlled heat and humidity (FSCDH-2PD models only), digital with readout or display, full view tempered glass sides, front and doors, perforated stainless steel

upper shelf, Swanstone base shelf, overhead lights, and cord and plug.

Accessories shall include circular perforated riser and stainless steel food pans.

One year on-site parts and labor warranty, plus one additional year parts-only warranty on all metal sheathed air heating elements with 24/7 parts and service assistance (U.S. and Canada only).

HATCO CORPORATION P.O. Box 340500 Milwaukee, WI 53234-0500 U.S.A. • (800) 558-0607 • (414) 671-6350
Fax (800) 543-7521 • Int'l. Fax (414) 671-3976 • www.hatcocorp.com • E-mail: equipsales@hatcocorp.com