



701 S Ridge Avenue, Troy, OH 45374  
1-888-4HOBART • www.hobartcorp.com

## DDU38<sub>e</sub> DIRECT DRIVE UNLOADER FOR CL<sub>e</sub> DISHWASHERS

### STANDARD FEATURES

- **DESIGN:** An accessory for any Hobart CL<sub>e</sub> Dishwasher. It is set up to be easily installed in the field. The DDU38<sub>e</sub> adds 38" to the length of the machine.
- **CONSTRUCTION:** Back, bottom and end shields of formed 14 gauge stainless steel with coved corners. Attached to the clean side of the dishwasher by stainless steel bolts. Unit has a 1½" drain connection and perforated stainless steel drain cover.
- **CONVEYOR:** Center pawl to be connected to dishwasher conveyor by means of a stainless steel adjustable rod. As conveyor drives, center pawl drives racks around 90 degree corner. The DDU38<sub>e</sub> is designed to move the racks at the same speed as the conveyor dishwasher speed.

### MODEL

- DDU38<sub>e</sub> – Direct Drive Unloader

Specifications, Details and Dimensions on Inside and Back.



**HOBART**

**DDU38<sub>e</sub> DIRECT DRIVE UNLOADER FOR CL<sub>e</sub> DISHWASHERS**

# DDU38<sub>e</sub> DIRECT DRIVE UNLOADER FOR CL<sub>e</sub> DISHWASHERS



701 S Ridge Avenue, Troy, OH 45374  
1-888-4HOBART • www.hobartcorp.com

## DETAILS AND DIMENSIONS

### LEFT TO RIGHT

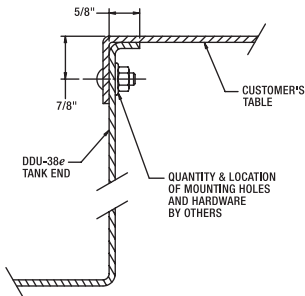

**SECTION B-B**  
SUGGESTED TABLE MOUNTING

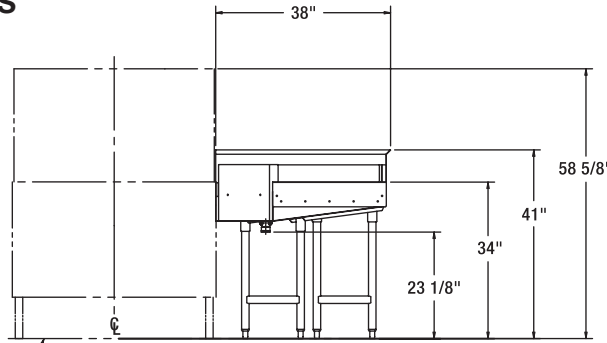

FLOOR LINE: ALL DIMENSIONS TAKEN FROM FLOOR LINE MAY BE INCREASED APPROX. 3/4" OR DECREASED 1/2".

MODEL	DIMENSION A
CL44 <sub>e</sub>	33"
CLPS66 <sub>e</sub>	33"
CL54 <sub>e</sub>	43"
CLPS76 <sub>e</sub>	43"
CL64 <sub>e</sub>	43"
CLPS86 <sub>e</sub>	43"

NOTES:  
1. FOR DIMENSIONS NOT SHOWN, SEE SPECIFICATION SHEET FOR MODEL SPECIFIED.

CL<sub>e</sub>  
DIRECT UNLOADER  
L-R OPERATION  
D-936646  
REV. B

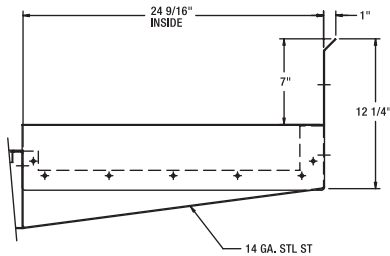

**VIEW A-A**  
VIEW LOOKING TOWARD UNLOADER TANK THROUGH CUSTOMER'S TABLE

**LEGEND**  
P1 DRAIN CONNECTION:  
1-1/2" FEMALE PIPE THREAD  
APPROX. 23-1/8" AFF



**WARNING**  
ELECTRICAL AND GROUNDING CONNECTIONS MUST COMPLY WITH THE APPLICABLE PORTIONS OF THE NATIONAL ELECTRICAL CODE AND/OR OTHER LOCAL ELECTRICAL CODES.

PLUMBING CONNECTIONS MUST COMPLY WITH APPLICABLE SANITARY, SAFETY, AND PLUMBING CODES.

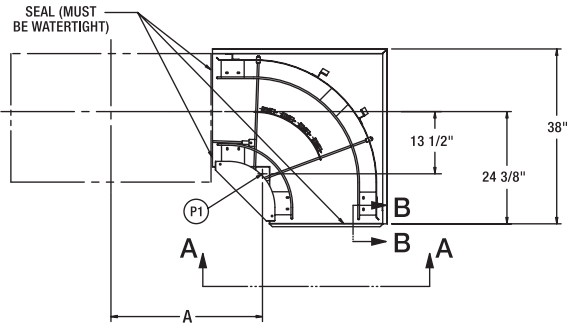

### RIGHT TO LEFT

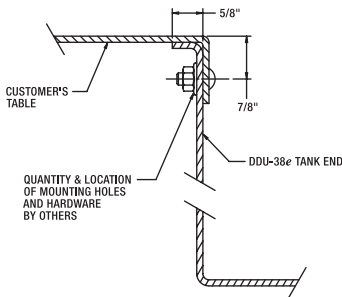

**SECTION B-B**  
SUGGESTED TABLE MOUNTING

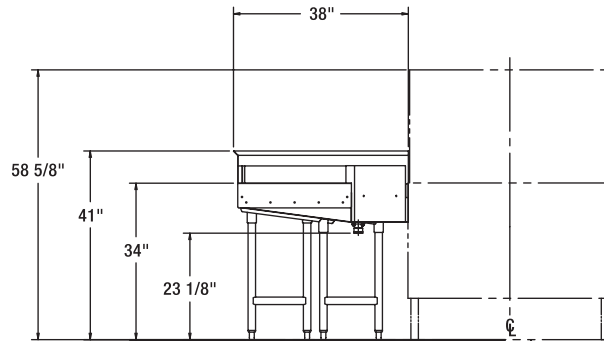

FLOOR LINE: ALL DIMENSIONS TAKEN FROM FLOOR LINE MAY BE INCREASED APPROX. 3/4" OR DECREASED 1/2".

MODEL	DIMENSION A
CL44 <sub>e</sub>	33"
CLPS66 <sub>e</sub>	33"
CL54 <sub>e</sub>	43"
CLPS76 <sub>e</sub>	43"
CL64 <sub>e</sub>	43"
CLPS86 <sub>e</sub>	43"

NOTES:  
1. FOR DIMENSIONS NOT SHOWN, SEE SPECIFICATION SHEET FOR MODEL SPECIFIED.

CL<sub>e</sub>  
DIRECT UNLOADER  
R-L OPERATION  
D-936645  
REV. B

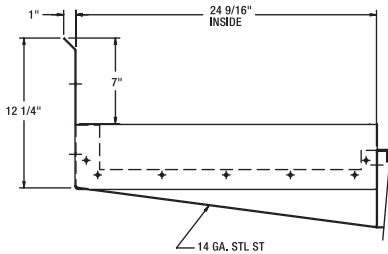

**VIEW A-A**  
VIEW LOOKING TOWARD UNLOADER TANK THROUGH CUSTOMER'S TABLE

**LEGEND**  
P1 DRAIN CONNECTION:  
1-1/2" FEMALE PIPE THREAD  
APPROX. 23-1/8" AFF



**WARNING**  
ELECTRICAL AND GROUNDING CONNECTIONS MUST COMPLY WITH THE APPLICABLE PORTIONS OF THE NATIONAL ELECTRICAL CODE AND/OR OTHER LOCAL ELECTRICAL CODES.

PLUMBING CONNECTIONS MUST COMPLY WITH APPLICABLE SANITARY, SAFETY, AND PLUMBING CODES.

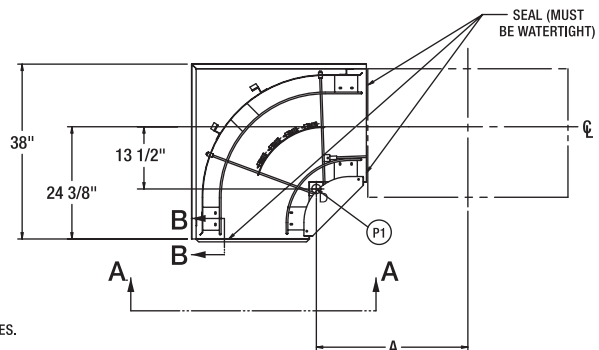

As continued product improvement is a policy of Hobart, specifications are subject to change without notice.