

**HOBART**701 S Ridge Avenue, Troy, OH 45374  
1-888-4HOBART • www.hobartcorp.com**FD500  
FOODWASTE DISPOSERS****HOBART****POWERFUL AND DEPENDABLE**

Peak periods for the large food service establishment can be very demanding on any foodwaste disposer. This powerful disposer has a large capacity for foodwaste. Hobart has engineered the 5 horsepower unit to perform dependably during peak demands for economical foodwaste disposal.

**SPECIFICATIONS**

Listed by Underwriters Laboratories Inc. and meets requirements of A.S.S.E. Standard No. 1009. (50 Hz. Electrical Specifications not available with thermal overload protection nor submitted for UL listing.)

**MOTORS:** Continuous duty rating. Permanently lubricated bearings (matched set double row tapered roller bearings for upper shaft thrust support, ball bearings for lower shaft support). Inherent overload protection in motor.

**HOUSINGS:** Heavy aluminum grind and discharge housings. Eight bolts fasten the motor unit to the grind chamber, permit easy removal.

**MOUNTING:** Disposer fastens to 7" I.D. throat opening cones. A vinyl isolating ring eliminates metal-to-metal contact at the cone mounting, reduces vibration and noise transmission.

**STATIONARY SHREDDER RING:** Ni-Hard, 2½" high, 4 machine ground primary action breaker bars, 42 secondary action grinding teeth.

**FLYWHEEL:** Breaker blade, mounted at center, speeds grinding, prevents objects from "riding" at center. Two hardened stainless steel cutter blocks (fastened to flywheel with Nyloc screws) are replaceable, can be indexed for new cutting edges. Ni-Resist flywheel is 9" diameter, slots undercut the shredder ring to assure that particles are cut to proper size before passing to the drain line.

**MOTOR SHAFT SEAL:** Face-type seal consists of sintered bronze mating ring and spring loaded carbon ring insert in chemical resistant neoprene bellows. Mating surfaces are protected from grit of fibers by being recessed into flywheel. Should any moisture pass this seal, a flinger and drain tube are provided to insure immediate removal. In addition, a lip-type oil seal (located beneath the bearings) is an "added protection" water seal.

**DRAIN CONNECTOR:** The removable outlet flange is tapped for 3" pipe connection.

**DUAL DIRECTION GRINDING:** Disposer flywheel operates in either direction. When installed with Control Groups 2 & 3, flywheel automatically starts in opposite direction each start. (Increases life and efficiency of grinding elements and frees flywheel of jams.)

**FD500 FOODWASTE DISPOSERS**





# FD500 FOODWASTE DISPOSERS



701 S Ridge Avenue, Troy, OH 45374  
1-888-4HOBART • www.hobartcorp.com

## ACCESSORY GROUPS

### GROUP A

-  Nitrile Rubber Scrapping Ring
-  Stainless Steel Silver-Saver Sleeve with Side Feed Hole
-  15" or 18" Cone
-  Water Swirl
-  Vacuum Breaker

### GROUP B

-  Nitrile Rubber Silver-Saver Splash Guard Ring
-  15" or 18" Cone
-  Water Swirl
-  Vacuum Breaker

### GROUP C

-  Nitrile Rubber Silver-Saver Splash Guard Ring
-  16" x 20" x 7" Stainless Steel Sink with Adapter and Water Inlet
-  Vacuum Breaker
-  Pre-Rinse Spray with Wall Bracket

### GROUP D

-  Nitrile Rubber Silver-Saver Splash Guard Ring
-  7" I.D. Stainless Steel Weld-in Adapter for Sink
-  Fixed Direction Water Inlet for Sink
-  Vacuum Breaker

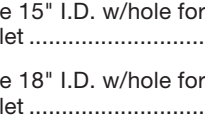
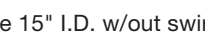
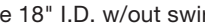

## ACCESSORY COMPONENTS

### CONES-SINK – Stainless Steel

- |  | Part No.   |
|--|--|
|   | Cone 15" I.D. w/hole for water swirl inlet .....ML-32664 |
|  | Cone 18" I.D. w/hole for water swirl inlet .....ML-32666 |
|                   | Cone 15" I.D. w/out swirl hole .... 315144               |
|                   | Cone 18" I.D. w/out swirl hole .... 315146               |

- |   |  |
|---|--|
|  | Sink 16" x 20" x 7" (7" opening) w/hole for water inlet.....ML-32662 |
|---|--|

### WATER INLETS

- |  |   |
|--|---|
|  | Cone Water Swirl Inlet 1/2" N.P.T. .... 315122                            |
|  | Fixed Direction Water Inlet (for sinks or troughs) 1/2" N.P.T..... 315142 |

### FLOW CONTROL

- |  |  |
|--|--|
|  | 10 Gallons per minute for Model FD-500 – 3/4" N.P.T. .... 315150 |
|--|--|

### CONE COVER – STAINLESS STEEL

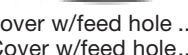
- |  |  |
|--|--|
|  | 15" Cone cover w/feed hole ...ML-33268 |
|  | 18" Cone Cover w/feed hole...ML-33269  |

### CONE FEEDING ACCESSORIES

- |   | Part No.   |
|---|--|
|  | Nitrile Rubber Scrapping Ring .... 292122                            |
|  | Stainless Steel Silver-Saver Sleeve with side feed hole ..... 315140 |

### SILVER-SAVER SPLASH GUARD RING

- |   |   |
|---|---|
|  | Nitrile Rubber Silver-Saver and Splash Guard Ring (for 7" opening cones, sinks and adapter)..... 315124 |
|---|---|

### SINK ADAPTER – Standard Group D Accessory

- |   |   |
|---|---|
|  | 7" I.D. Stainless Steel Adapter for Welding to Sink or Trough..... 292123 |
|---|---|

### VACUUM BREAKERS – Luster Chrome Plated

- |   |                   |
|---|-------------------|
|  | 3/4" ..... 315138 |
|---|-------------------|

### PRE-RINSE SPRAYS

- |   |  |
|---|--|
|  | PR-3 Heavy-duty Flexible Pre-rinse Spray (40" high with wall bracket) ML-32333 |
|---|--|

- |   |   |
|---|---|
|  | PR-4 Utility Spray (with wall bracket) ML-32334 |
|---|---|

Adapters are available to install Hobart Disposers on existing cones. See Form F-7543



701 S Ridge Avenue, Troy, OH 45374  
1-888-4HOBART • www.hobartcorp.com

# FD500 FOODWASTE DISPOSERS

**ELECTRICAL CONTROL GROUPS** Listed by Underwriters Laboratories Inc., for use with FD Disposers (50 Hz. Electrical Specifications not submitted for UL Listing.)

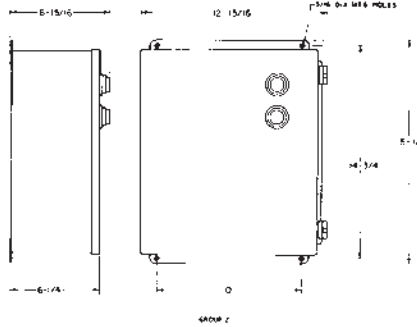

**Group 2**  
Includes:  
Magnetic Contactors  
Pushbutton Start and Stop  
Automatic Reversing  
NEMA 12 Enclosure  
Solenoid Valve

Approximate  
Shipping Wt. 31 lbs.

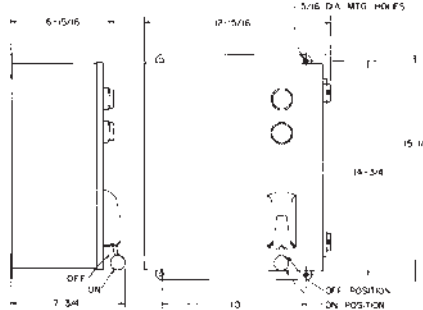

**Group 3**  
Includes:  
Magnetic Contactors  
Pushbutton Start and Stop  
Automatic Reversing  
Low Water Pressure Cut-off  
Time Delay for water after shut-off  
Line Disconnect  
Solenoid Valve  
NEMA 12 Enclosure

Approximate  
Shipping Wt. 38 lbs.

### AVAILABLE ELECTRICAL SPECIFICATIONS

5.H.P., 3 Phase

Hz.	VOLTS	RATED AMPS
60	200-230/460	12.8/6.4
50	220-240/380-415	11.6/6.7

The slant (/) line indicates the dual voltage operation accomplished by motor lead connections; follow connecting diagram on motor.

### SAMPLE SPECIFICATION

FD-500 — B — 2 (230/60/3)

Electrical Specifications

Electrical Control Group

Accessory Group

Model Number

Cut hole 19" for 18" cone. Hole to be 16" for 15" cone.

Solenoid must be installed in upright position.

Disposer may be easily rotated for better drain line connection.

Center line at wall outlet of trap should not be higher than center line of disposer discharge opening.

If water pressure is in excess of 60 P.S.I. install a pressure reducing valve.

# FD500 FOODWASTE DISPOSERS



701 S Ridge Avenue, Troy, OH 45374  
1-888-4HOBART • www.hobartcorp.com

## DETAILS AND DIMENSIONS

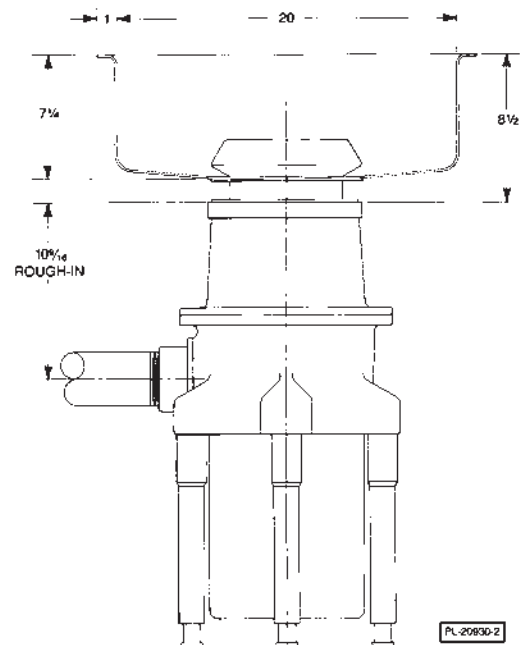
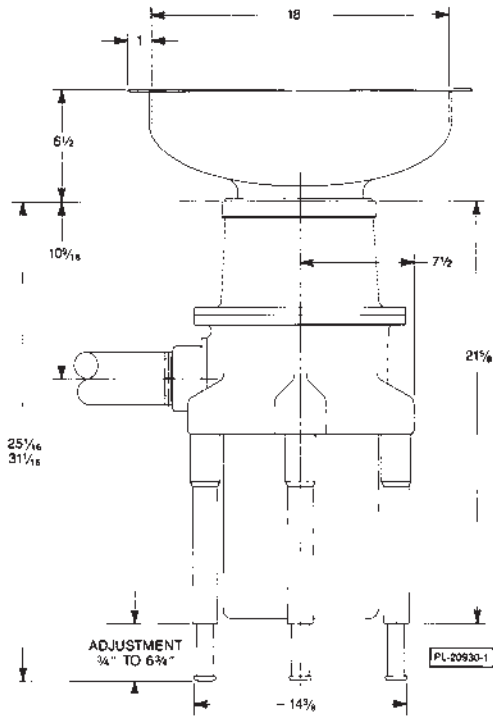

NOTE: Accessory Groups A and B ... 18" Cone is Standard. Specify 15" Cone in Place of 18" Cone When Desired.

## TYPICAL INSTALLATION

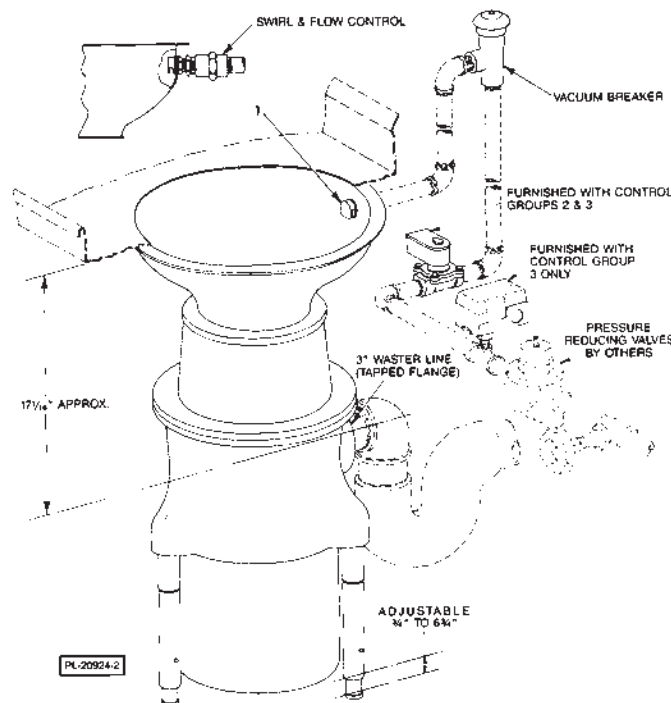

As continued product improvement is a policy of Hobart, specifications are subject to change without notice.