

HOBART701 S Ridge Avenue, Troy, OH 45374
1-888-4HOBART • www.hobartcorp.com**PW10/PW10eR
DISHMACHINE****HOBART****STANDARD FEATURES**

- | | 2 Minute Wash | 4 Minute Wash | 6 Minute Wash |
|--------|---------------|---------------|---------------|
| PW10 | 20 | 12 | 8 |
| PW10eR | 13 | 9 | 7 |
- Racks per hour –
 - 1.2 gallons of water per cycle
 - Timed wash cycles for 2-4-6 minutes
 - Hot water sanitation machines
 - Steam Elimination and Energy Recovery (Advansys only)
 - Sense-A-Temp™ booster heater capable of 70° rise
 - Front loading, split-door configuration
 - Chamber accepts 10 full-sized sheet pans, or 140 quart mixing bowl
 - Advanced Service diagnostics
 - Advanced Delime notification and cycle (includes booster) (Advansys only)
 - 16 gauge stainless steel deep drawn tank
 - Microcomputer controls with advanced digital cycle/temperature display
 - Two revolving upper and lower anti-clogging wash arms and rinse arms
 - Removable stainless steel scrap screens and scrap basket
 - Corrosion resistant pump
 - Automatic pumped drain
 - Pumped rinse
 - 33.79" door opening
 - Automatic fill
 - Delime pump standard (Advansys)
 - Electric tank heat
 - Spray hose

STANDARD VOLTAGES

- 208/60/3
- 480/60/3

MODELS

- PW10
- PW10eR

ACCESSORIES

- Pressure regulator valve
- DWT-PW drain water tempering kit

Specifications, Details and Dimensions on Inside and Back.



PW10

PW10eR

PW10/PW10eR DISHMACHINE

PW10 DISHMACHINE



701 S Ridge Avenue, Troy, OH 45374
1-888-4HOBART • www.hobartcorp.com

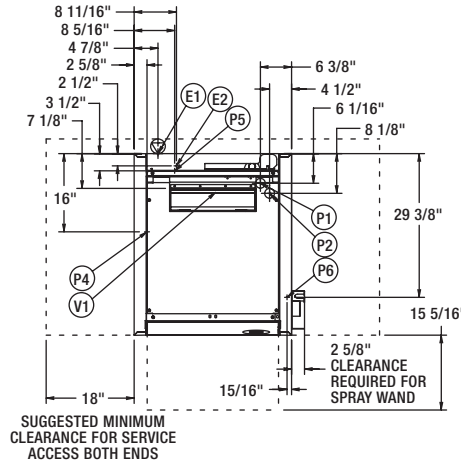

⚠ WARNING

Electrical and grounding connections must comply with the applicable portions of the National Electrical Code and/or other local electrical codes.

Plumbing connections must comply with applicable sanitary, safety and plumbing codes. Drain and fill line configurations vary, some methods are shown on this drawing.

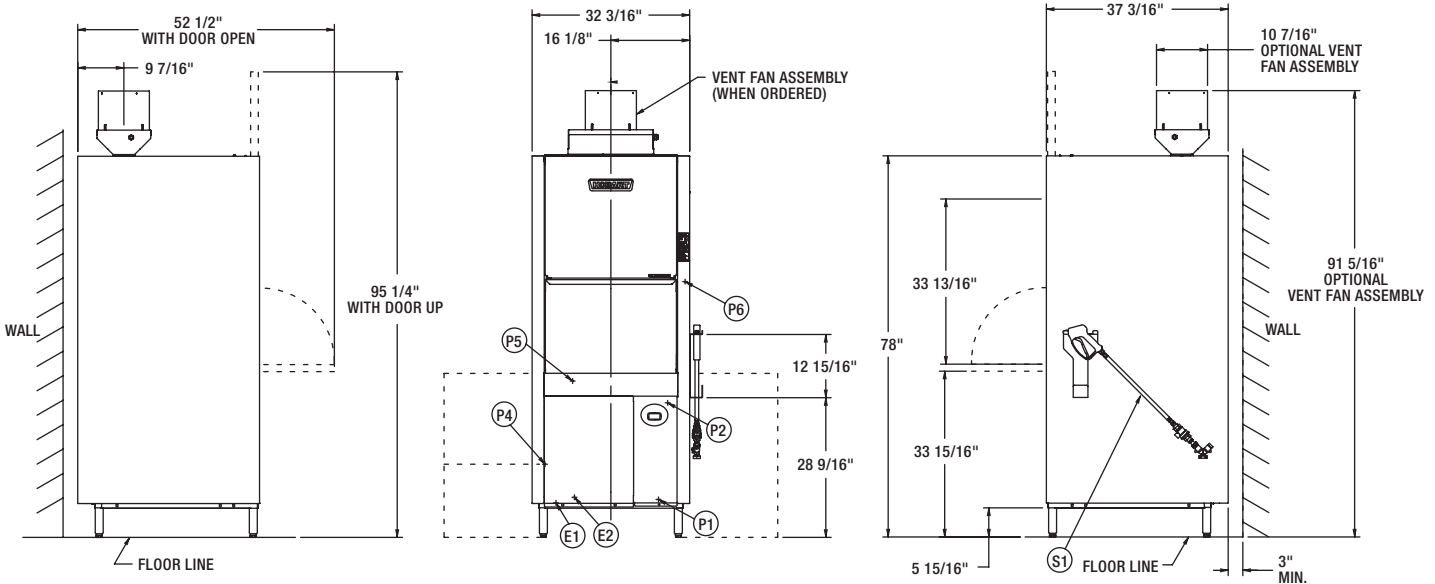

PLUMBING NOTES:

Required flowing water pressure to the dishmachine is 15-65 PSIG. If pressures higher than 65 PSIG are present, a pressure regulating valve must be installed in the water line to the dishmachine (by others).
Recommended water hardness to be 3 grains or less for best results.
Pressure gauge not required on pumped rinse machines.

MISCELLANEOUS NOTES:

Backflow prevention provided by NSF-approved air gap device
Single point electrical connection machines.
All dimensions taken from floor line may increase 1-1/2" depending on leg adjustment.
Net weight of machine: 324 LBS.
Domestic shipping weight: 387 LBS.
Shipping dimensions:
79-1/8"H X 40-1/4"W X 40"D.
Size of racks:
23-3/4" X 26-5/8" X 2-1/4"

CONNECTION INFORMATION (*AFF - ABOVE FINISHED FLOOR)

LEGEND

- E1 ELECTRICAL CONNECTION (INCLUDING ELECTRIC HEAT)
1-1/4" CONDUIT HOLE, 7-1/16" AFF.
- E2 ELECTRICAL CONNECTION: DETERGENT/RINSE AGENT FEEDERS;
8-3/16" AFF.
- P1 HOT WATER CONNECTION INCOMING: 110°F WATER MIN.
3/4" FEMALE GARDEN HOSE FITTING ON 6' LONG HOSE
SUPPLIED WITH MACHINE. 7-3/4" AFF.
- P2 DRAIN CONNECTION: 7/8" BARB FITTING, 27-3/8" AFF.
6' LONG 7/8" HOSE SUPPLIED WITH MACHINE.
- P4 DETERGENT PROBE SENSOR; 14-11/16" AFF.
- P5 DETERGENT FEEDER; 31-15/16" AFF.
- P6 RINSE AGENT FEEDER; 52-5/16" AFF.
- V1 VENT EXIT: 4-9/16" X 17-3/8" EXHAUST (STANDARD)
TO ALLOW FOR EXPANSION OF AIR.(NEED NOT BE
CONNECTED TO EXTERNAL VENT); IF REQUIRED, VENT FAN
ASSEMBLY TO PROVIDE 400 CFM EXHAUST.
- S1 110°F MIN., 3/4" FEMALE GARDEN HOSE TEE FITTING ON
12' LONG HOSE SUPPLIED WITH MACHINE. MOUNTABLE
ON EITHER SIDE.

ELEC. SPECS.	RATED AMPS	MINIMUM SUPPLY CIRCUIT CONDUCTOR AMPACITY	MAXIMUM OVERCURRENT PROTECTIVE DEVICE
208/60/3	47.6	60	60
240/60/3	53.0	70	70
480/60/3	28.6	35	35

MODEL: PW10
ELECTRIC
00-950647
REV B



701 S Ridge Avenue, Troy, OH 45374
1-888-4HOBART • www.hobartcorp.com

PW10eR DISHMACHINE

WARNING

Electrical and grounding connections must comply with the applicable portions of the National Electrical Code and/or other local electrical codes.

Plumbing connections must comply with applicable sanitary, safety and plumbing codes. Drain and fill line configurations vary, some methods are shown on this drawing.

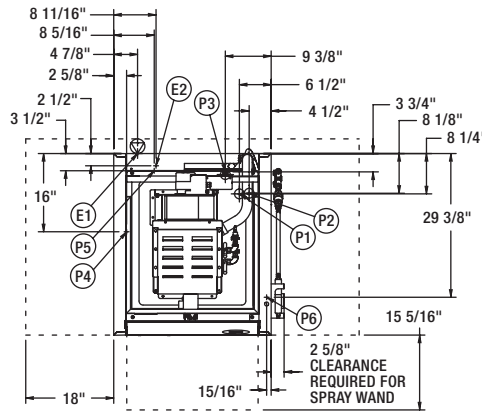

SUGGESTED MINIMUM CLEARANCE FOR SERVICE ACCESS BOTH ENDS

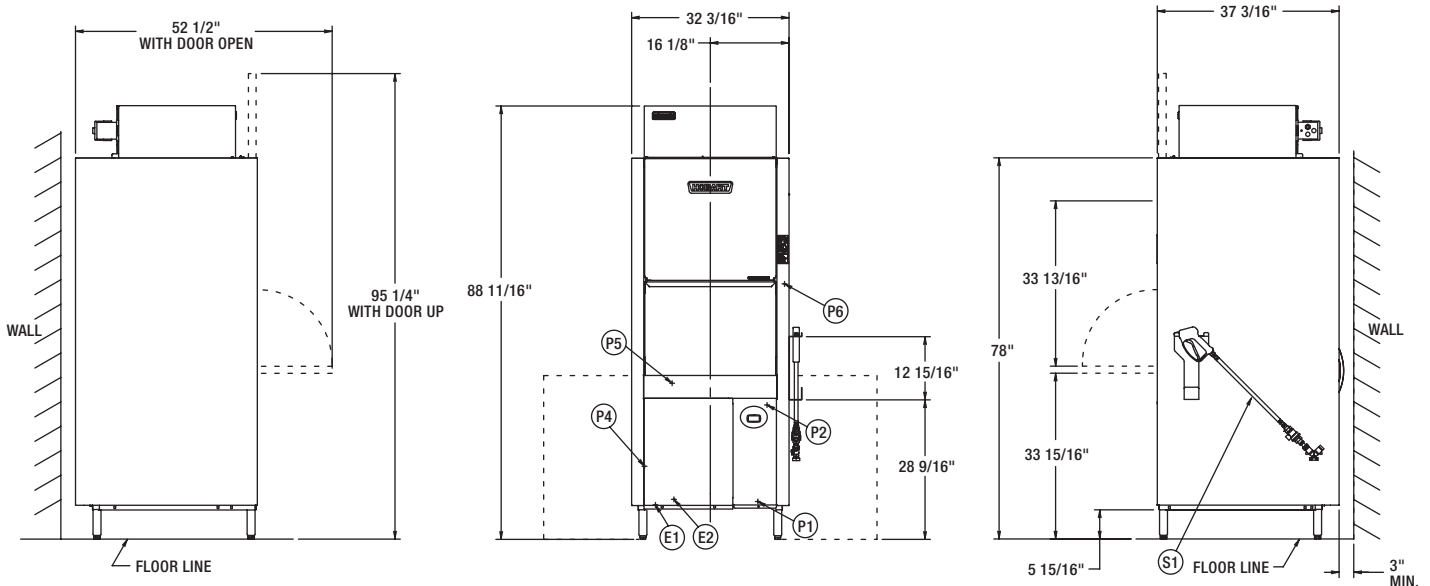

PLUMBING NOTES:

Required flowing water pressure to the dishmachine is 15-65 PSIG. If pressures higher than 65 PSIG are present, a pressure regulating valve must be installed in the water line to the dishmachine (by others).

Recommended water hardness to be 3 grains or less for best results.

Pressure gauge not required on pumped rinse machines.

MISCELLANEOUS NOTES:

Backflow prevention provided by NSF-approved air gap device

Single point electrical connection machines.

APPROXIMATE HEAT GAIN TO SPACE WITHOUT VENT HOOD			
MODEL	VOLTAGE	TYPE	BTU/HR
PW10eR	208	LATENT	16,200
		SENSIBLE	10,000
	240/480	LATENT	20,100
		SENSIBLE	12,300

Vent hood is not required due to internal condensing system.

All dimensions taken from floor line may increase 1-1/2" depending on leg adjustment.

Net weight of machine: 512 LBS.

Domestic shipping weight: 575 LBS.

Shipping dimensions:

89-3/4" H X 40-1/4" W X 40" D.

Size of racks:

23-3/4" X 26-11/16" X 2-1/4"

CONNECTION INFORMATION (*AFF - ABOVE FINISHED FLOOR)

LEGEND

- E1 ELECTRICAL CONNECTION (INCLUDING ELECTRIC HEAT)
1-1/4" CONDUIT HOLE, 7-1/16" AFF.
- E2 ELECTRICAL CONNECTION: DETERGENT/RINSE AGENT FEEDERS;
8-3/16" AFF.
- P1 HOT WATER CONNECTION INCOMING: 110°F WATER MIN.
3/4" FEMALE GARDEN HOSE FITTING ON 6' LONG HOSE
SUPPLIED WITH MACHINE. 7-3/4" AFF.
- P2 DRAIN CONNECTION: 7/8" BARB FITTING, 27-1/2" AFF.
6' LONG 7/8" HOSE SUPPLIED WITH MACHINE.
- P3 COLD WATER CONNECTION INCOMING: 90°F WATER MAX.
(65°F OPTIMAL), 3/4" FEMALE GARDEN HOSE FITTING ON
6' LONG HOSE SUPPLIED WITH MACHINE. 7-3/4" AFF.
- P4 DETERGENT PROBE SENSOR; 14-11/16" AFF.
- P5 DETERGENT FEEDER; 31-15/16" AFF.
- P6 RINSE AGENT FEEDER: 52-5/16" AFF.
- S1 110°F MIN., 3/4" FEMALE GARDEN HOSE TEE FITTING ON
12' LONG HOSE SUPPLIED WITH MACHINE. MOUNTABLE
ON EITHER SIDE.

ELEC. SPECS.	RATED AMPS	MINIMUM SUPPLY CIRCUIT CONDUCTOR AMPACITY	MAXIMUM OVERCURRENT PROTECTIVE DEVICE
208/60/3	47.6	60	60
240/60/3	53.0	70	70
480/60/3	28.6	35	35

MODEL: PW10eR
ELECTRIC
00-950647
REV B

PW10/PW10eR DISHMACHINE



701 S Ridge Avenue, Troy, OH 45374
1-888-4HOBART • www.hobartcorp.com

SPECIFICATIONS

DESIGN: Heavy duty, fully automatic, front opening Prep Washer with split-door system. Upper door section slides upward as the lower door section is pulled down. Stainless steel pull-out rack allows easy loading for large utensils and pans. Three variable wash cycles ensure thorough cleaning and sanitizing

CONSTRUCTION: Stainless steel tank and chamber, door, frame, legs and adjustable feet.

PUMP: Pump capacity 211 gpm.

MOTOR: 208-240/60/3 or 480/60/3 configurations. Factory sealed lubrication, TEFC with sealed ball bearings. Thermal overload protection.

WASH AND RINSE CYCLE: Complete automatic type, controlled by microprocessor electronics. Cycle may be interrupted any time by opening door. Cycle continues when door is closed.

- Initial cycle fills wash tank, to be recirculated each wash cycle. Some wash water is drained off before rinse cycle. Rinse cycle refreshes wash water and tank heat.

RINSE PUMP: Powered by a 1/8 H.P. 3Ø TEFC motor, the rinse pump is made of high strength engineered composite material.

BLOWER: The condenser blower is an all stainless steel forward curved centrifugal wheel powered by a 1/16 H.P. TEFC single phase motor for nearly silent operation.

CONDENSER COIL: The condensing system using a tube and fin coil constructed of copper and corrosion resistant aluminum.

ELECTRIC BOOSTER HEATER: Electric booster with Sense-A-Temp™ technology adequately sized to raise 110° inlet water to 180°.

CYCLE OPERATION:

PW10eR: The microcomputer-timing program is started by closing the doors and actuating the wash cycle button. The microcomputer energizes the wash pump motor contactor during the wash portion of the program. After the wash, a dwell permits the upper wash manifold to drain. At the end of the dwell, the final rinse pump is energized. After the final rinse pump turns off, the Blower and Cold Water Valve turn on for 120 seconds to condense the vapor laden air inside the chamber. After 120-140 seconds is complete the Cycle Light turns OFF, completing the program.

PW10: The microcomputer-timing program is started by closing the doors and actuating the wash cycle button. The microcomputer energizes the wash pump motor contactor during the wash portion of the program. After the wash, a dwell permits the upper wash manifold to drain. At the end of the dwell, the final rinse pump is energized. After the final rinse pump turns off, Sani-Dwell permits sanitization to continue, completing the cycle.

RINSE AND SANITATION:

- **PW10/10eR:** Sanitation is accomplished by means of a built-in booster heater designed to raise temperature of water to a minimum of 180°F from an incoming water temperature of 110°F for PW10 and 55°F for PW10eR.

ENERGY RECOVERY: Heat energy is recovered from the condensation of vapors in the chamber at the end of each cycle. This pre-heats the water for the next rinse cycle from 55°F up to 140°F.

PUMPED DRAIN: Machine automatically drains water through a built-in pump. Maximum 38" drain height permitted.

RACKING: Standard rack assortment consists of one flat-bottomed frame rack, one flat grid insert rack and one tray support insert rack.

SPECIFICATIONS: Listed by Underwriters Laboratories Inc. and NSF International.

MACHINE RATINGS	PW10			PW10eR		
	2 Minute Wash	4 Minute Wash	6 Minute Wash	2 Minute Wash	4 Minute Wash	6 Minute Wash
Racks per Hour Rate	20	12	8	13	9	7
Tank Capacity - Gallons	21 gallons					
Overall Dimensions - H x W x D	78.04" H x 34.86" W x 37.20" D			88.47" H x 34.86" W x 37.20" D		
Wash Cycle Time - Minutes	2, 4, 6 minutes					
Water Usage Per Cycle - Gallons	1.2 gallons					
Drain Design	Pumped					
Door Opening Height x Width	33.79" H x 26.185" W					
Chemical Connection Capability	Standard					
Delime Pump	N/A			Standard		
Peak Drain Flow - GPM	18					
Advanced Service Diagnostics	N/A			Standard		
Advanced Cleaning Cycle	N/A			Standard		
70° Rise Sense-A-Temp™ Booster Heater	Standard					
Incoming Water Temperature Required (minimum)	110°			55°		

As continued product improvement is a policy of Hobart, specifications are subject to change without notice.