

C-100BAF-(AD)DS*

SELF-CONTAINED CUBELET WITH BUILT-IN STORAGE BIN (ADA Compliant with Customized Door System)

Item # _____

Project: _____

Qty: _____

*AutoCad available on KCL

C-100BAF-(AD)DS

I/13

Item # 13277

CUBELET DIMENSIONS

W x D x H

C-100BAF

14^{7/8} x 22^{5/8} x 33^{1/2}

C-100BAF-AD

14^{7/8} x 22^{5/8} x 31^{1/2}

C-100BAF-DS

14^{7/8} x 22^{5/8} x 33^{1/2}

C-100BAF-ADDS

14^{7/8} x 22^{5/8} x 31^{1/2}

*DS - Designed to accommodate custom cabinetry to affix to stainless door.

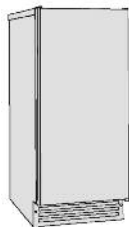

C-100BAF-(DS)

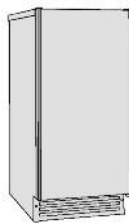

C-100BAF-AD(DS)

C-100BAF

Air-Cooled
Shown

C-100BAF-AD

Air-Cooled
ADA Compliant Unit



C-100BAF-DS*

Air-Cooled
Shown
with Custom Cabinetry

C-100BAF-ADDS*

Air-Cooled
ADA Compliant Unit



*Customer responsible for providing cabinetry

C-100BAF & C-100BAF-DS

- Undercounter design is less than 34 inches tall

C-100BAF-AD & C-100BAF-ADDS

- Undercounter design is less than 32 inches tall, which complies with the Americans with Disabilities Act (ADA)

C-100BAF(-DS) & C-100BAF-AD(DS)

- Up to 92 lbs. of ice production per 24 hours
- UL approval for outdoor use
- Up to 22 lbs. of built-in storage capacity
- Power switch accessible without panel removal
- Easily disassembled water circuit for easy cleaning
- Front in, front out airflow
- Fewer moving parts for longer life
- Swing style reversible door
- Side and top trim kit available
- Accessory - HS-5061 Drain Pump Assembly
- R-134A Refrigerant

* The C-100BAF, C-100BAF-AD, C-100BAF(-DS) and C-100BAF-AD(DS) are ENERGY STAR qualified.

Warranty

Valid in United States, Canada, Puerto Rico, & U.S. Territories. Contact factory for warranty in other countries.

Two Year - Parts & Labor on entire machine.

One Year - HS-5061 Drain Pump Assembly - Parts & Labor.



ISO9001-15014:2001



C-100BAF-(AD)DS SELF-CONTAINED CUBELET WITH BUILT-IN STORAGE BIN

DIMENSIONS W x D x H

C-100BAF / C-100BAF-DS
14^{7/8} x 22^{5/8} x 33^{1/2}

C-100BAF-AD / C-100BAF-ADDS
14^{7/8} x 22^{5/8} x 31^{1/2}

- Air-cooled
- ADA compliant

AIR-COOLED

Water Temp ° F.	50°	70°	90°
Air Temp ° F.			
70°	92	89	84
80°	81	71	66
90°	66	62	57

UTILITY CONSUMPTION (AIR 70°F/WATER 50°F)

Model Number	KWH per 100 LBS.	Potable Water Gal. per 100 lbs.	Condenser Water Gal. per 100 lbs.
C-100BAF-(AD)DS	12.1	12	N/A

SPECIFICATIONS

Model Number	Condenser	Amperage	Min. Circuit Ampacity	Shipping Weight
C-100BAF-(AD)DS	Air-Cooled	4.0	15	115 lbs.*

* Without pallet

CUBELET DIMENSIONS

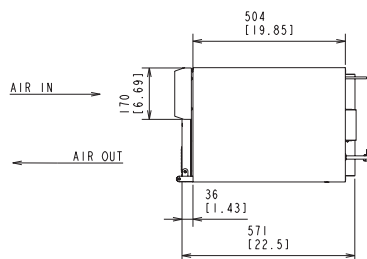
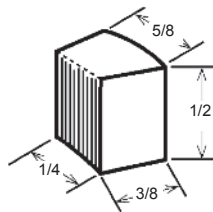

TOP DIMENSIONS

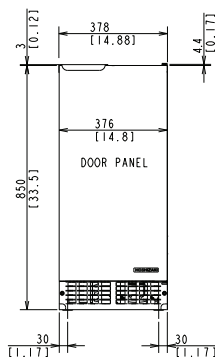

FRONT DIMENSIONS

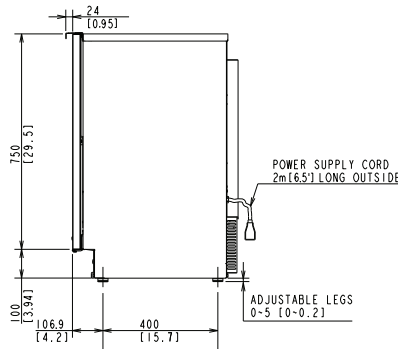

SIDE DIMENSIONS

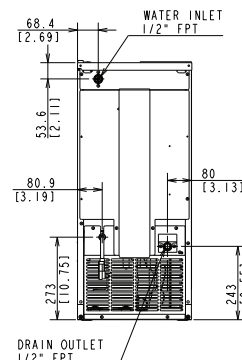

BACK DIMENSIONS

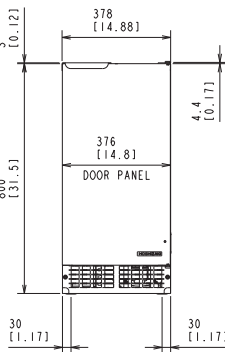

FRONT DIMENSIONS
(ADA compliant unit)

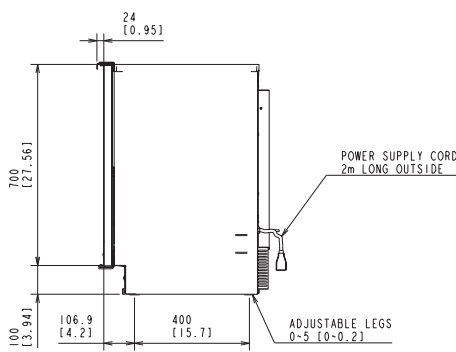

SIDE DIMENSIONS
(ADA compliant unit)

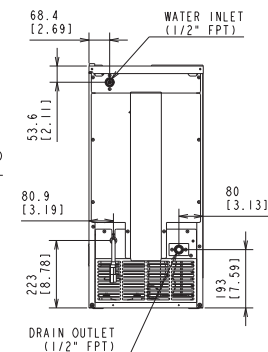

BACK DIMENSIONS
(ADA compliant unit)

ELECTRICAL & PLUMBING/C-100BAF-AD(DS)

- 115V/60/1
- 15 amp Max Fuse/HACR Breaker Size
- 1/2" FPT Water Inlet
- 1/2" FPT Drain



© HOSHIZAKI AMERICA, INC.

618 Hwy. 74 S., Peachtree City, GA 30269

OPERATING LIMITS

- Ambient Temp Range 45 - 100°F
- Water Temp Range 45 - 90°F
- Water Pressure 7 - 113psig
- Voltage Range 104 - 127V

TEL 1-800-438-6087

FAX 1-800-345-1325

www.hoshizaki.com

Printed in U.S.A.

