



# CRMR27-8D

## Commercial Series Sandwich Top Refrigerator with Drawers

CRMR27-8D  
6/14  
Item #13332



Hoshizaki America, Inc. reserves the right to change specifications without notice.

Item #

Project:

Qty:

\*AutoCad available on KCL

### CRMR-D Dimensions W x D x H

I Section - 27" x 30" x 45.2"\*

\*with 6" casters

### Electrical/Refrigeration

Voltage 115/60/1

HACR Breaker

I Section - 15.0

Electrical Connection (NEMA)

I Section - 5-15P

Voltage Range 104-126

Ambient Temp. Range 45° to 86°F

Temperature Range 32° to 52°F

\*Refrigerant R-134a

### Warranty

Valid in United States, Canada, Puerto Rico, and U.S. Territories. Contact factory for warranty in other countries.

- **Three Year** - Parts & Labor on entire machine.
- **Five Year** - Parts on: Compressor.

### Options

- 2" Casters
- 4" Casters
- 6" Legs
- Flat lift off stainless steel cover
- Stainless steel back



- Stainless steel exterior front, sides and top
- Anodized Aluminum interior sides and back with stainless steel interior floor
- Front breathing air flow design
- Stainless steel exterior drawer with ABS interior liner
- Cabinet and drawers are insulated with 2" foamed in place polyurethane
- Drawer slides are constructed of 16 gauge stainless steel with acetal rollers
- Drawers will accommodate (1) 12" x 20" x 6" deep pan (pans by others)
- Extruded aluminum flush mount drawer handle
- Magnetic drawer gasket is easily removable for cleaning
- 1/2" thick full length white polyethylene cutting board is standard
- Provided with a full complement of polycarbonate plastic 1/6th size pans, 4" deep
- Enamel coated evaporator coil
- Standard with 6" stem casters (two with brakes)
- Three years parts and labor warranty
- Five year compressor warranty
- 8 ft. cord and plug

### Dimensions / Capacity

Model #	One Section CRMR27-8D
Interior Storage Capacity (CF)	7.2 ft <sup>3</sup>
Overall Width x Depth	27" x 30"
Height (including 6" casters)	45.2"
Depth with Cutting Board Installed	30.7"
Drawer Opening Width x Height	22.6" x 22.9"
Depth with Drawer Fully Open	43.25"
Drawer Pan Capacity (12" x 20" x 6" DP Pans)	1 pan per drawer
Pan Capacity (# of 1/6 size x 4" deep)	8
Maximum Pan Depth	6"
Crated Shipping Weight	205 lbs
Crated Height x Width x Depth	45.1" x 31.5" x 34"

### Electrical / Refrigeration Data

Model #	One Section CRMR27-8D
Amperage	2.6
Energy Consumption (kwh/day) NSF	1.6
Heat Rejection (BTU/Hr.) @NSF	230
Approx. Nominal Compres. BTU/HR(HP)	1029(1/6HP)



© HOSHIZAKI AMERICA, INC.

618 Hwy. 74 S., Peachtree City, GA 30269  
TEL 800-438-6087  
FAX 800-345-1325  
www.hoshizaki.com



# CRMR27-8D

Commercial Series Sandwich Top Refrigerator with Drawers

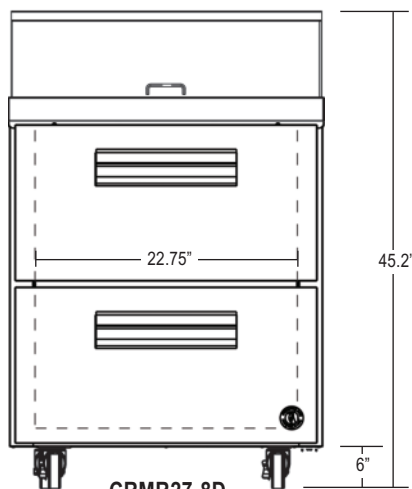

CRMR27-8D  
FRONT

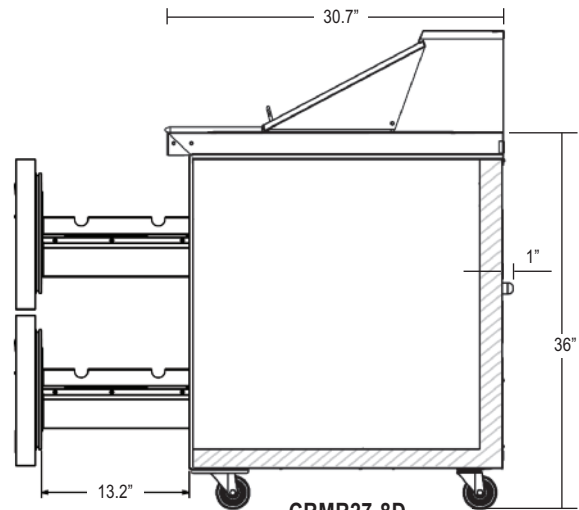

CRMR27-8D  
SIDE  
(Cross Section)

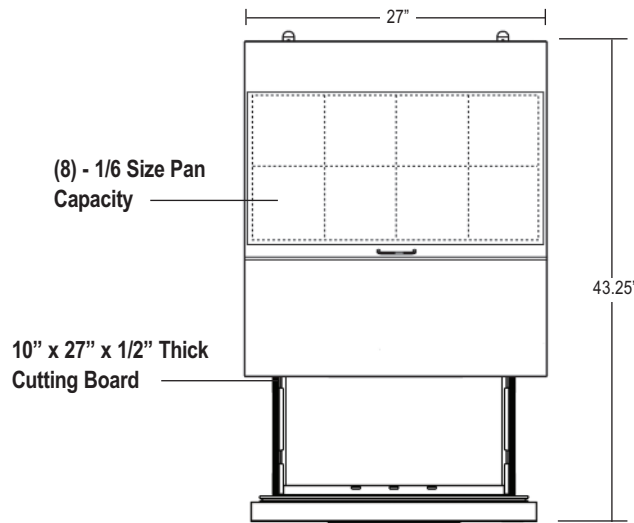

(8) - 1/6 Size Pan Capacity

10" x 27" x 1/2" Thick Cutting Board

CRMR27-8D  
FRONT

## Cabinet Construction

The exterior cabinet top, front, and sides, are constructed of high quality stainless steel. Cabinet is provided with a stainless steel top enclosure and an easily removable insulated lift-up cover. The exterior back and bottom are constructed of coated steel. The cabinet interior back and sides are anodized aluminum with an ABS ceiling and stainless steel floor. Cabinet walls and drawers are insulated with 2" of environmentally friendly, CFC free, foamed in place polyurethane. 6" polyolefin, stem casters (two with brakes) are standard. Preparation tables are supplied with 1/2" thick full length N.S.F. approved white polyethylene cutting board as standard.

## Drawer Construction

Drawer fronts are constructed of high grade stainless steel inside with ABS interior liners and are insulated with R-134a CFC free foamed in place polyurethane. Each drawer accommodates (1) 12" x 20" x 6" deep pan (pans by others). Drawer frames are formed of 14 gauge stainless steel and securely fastened in the cabinet. The drawer slides are 16 gauge stainless steel with acetal rollers to prevent metal to metal contact between the drawer slides and reduce wear. The drawer slides have a dynamic load capacity of 175 lbs. and have been life tested (fully loaded) three hundred thousand openings and closings without showing significant wear. The flush mount handles are constructed of extruded aluminum. Snap-in magnetic drawer gaskets are durable and easily removed for cleaning.

## Refrigeration System

Front breathing refrigeration system allows unit to be built in to any enclosure with zero side and rear clearance. The high efficiency refrigeration system is self-contained with an enamel coated evaporator for extended life. Condensate removal is accomplished with an energy efficient non-electric evaporation system. A capillary tube controls the flow of environmentally friendly R-134A refrigerant through the evaporator. Refrigeration system utilizes an "off cycle" and timer-initiated defrost to eliminate any ice on the evaporator coil. An innovative air distribution duct distributes air evenly around the pans. Product temperatures are maintained between 33°F and 41°F at 86° ambient room temperature to comply with N.S.F.7. Preparation tables are supplied with a full complement of N.S.F. approved polycarbonate plastic 1/6<sup>th</sup> size pans, 4" deep and stainless steel adapter bars. Units will accommodate 6" deep pans. Pans are located 1.5" below the top to keep food product within easy reach. 115 volt units are equipped with an eight foot cord and NEMA rated plug (20.0 amps or less).

© HOSHIZAKI AMERICA, INC.

618 Hwy. 74 S., Peachtree City, GA 30269 • TEL 800-438-6087 • FAX 800-345-1325 • www.hoshizaki.com



Intertek Intertek

ISO 9001 · ISO 14001