

# DCM-751B\_H

## SANITARY CUBELET ICE MACHINE/DISPENSER

Item # \_\_\_\_\_

Project: \_\_\_\_\_

Qty: \_\_\_\_\_

\*AutoCad available on KCL

DCM-751B\_H

5/12

Item # 13290

### DIMENSIONS

W x D x H

#### DCM-751B\_H

34<sup>1/16</sup> x 28<sup>1/2</sup> x 48<sup>1/16</sup>

#### SD-700

34<sup>1/4</sup> x 28<sup>1/4</sup> x 32<sup>1/2</sup>

#### SD-750

34 x 28 x 32<sup>3/4</sup>



### DCM-751BAH

Air-Cooled

Shown on an optional

### SD-750 Stand

### DCM-751BWH

Water-Cooled

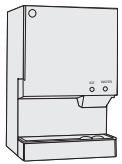

DCM-751  
Countertop



DCM-751  
Countertop  
with optional  
6" legs

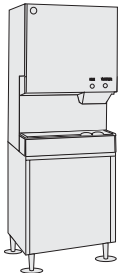

DCM-751  
Floor Model  
with optional  
stand

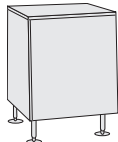

SD-700  
optional  
stand



SD-750  
optional  
stand

### DCM-751B\_H

- CleanCycle12® - Every 12 hours, unit performs 15 minute purge to rid itself of impurities



- Corrosion resistant stainless steel exterior
- Up to 801 lbs. of ice production per 24 hours, with 95 lbs. built-in storage
- Easy to chew, cubelet ice
- Self contained design reducing opportunities for cross contamination
- Dispenses ice and water
- Removable air filters (Air-cooled model only)
- Protected by H-GUARD Plus Antimicrobial Agent



### SD-700 Stand / SD-750 Stand

- Heavy duty stand for floor model icemaker/dispenser
- Corrosion resistant stainless steel exterior
- Easy cleaning with attractive appearance
- Locking doors standard on SD-750



ISO9001-ISO14001

### Warranty

Valid in United States, Canada, Puerto Rico, & U.S. Territories. Contact factory for warranty in other countries.

**Three Year** - Parts & Labor on entire machine. (Serial numbers VxxxxxJ and after.)

**Five Year** - Parts on: Compressor, air-cooled condenser.



# DCM-75IB\_H SANITARY CUBELET ICE MACHINE/DISPENSER

## DIMENSIONS W x D x H

<b>DCM-75IB_H</b>	34 <sup>1/16</sup> x 28 <sup>1/2</sup> x 54 <sup>1/16</sup>
<b>SD-700</b>	34 <sup>1/4</sup> x 28 <sup>1/4</sup> x 32 <sup>1/2</sup>
<b>SD-750</b>	34 x 28 x 32 <sup>3/4</sup>

- Sanitary Cubelet ice machine/dispenser
- Optional stand
- Optional stand with locking doors

## AIR-COOLED

Water Temp° F.	50°	70°	90°	
Air Temp° F.	70°	801	757	725
80°	695	666	639	
90°	612	<b>583</b>	562	

## WATER-COOLED

Water Temp° F.	50°	70°	90°	
Air Temp° F.	70°	800	779	758
80°	738	719	700	
90°	681	<b>685</b>	646	

## UTILITY CONSUMPTION

Model Number	KWH per 100 LBS. 90/70	Potable Water Gal. per 100 lbs.
DCM-751BAH	5.94	12.0
DCM-751BWH	4.77	12.0

## SPECIFICATIONS

Model Number	Condenser	Min. Circuit Ampacity	Shipping Weight
DCM-751BAH	Air-Cooled	20	345 lbs.
DCM-751BWH	Water-Cooled	20	345 lbs.
SD-700	N/A	N/A	165 lbs.
SD-750	N/A	N/A	125 lbs.

## CUBELET DIMENSIONS

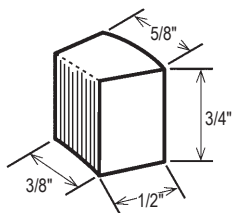

## ELECTRICAL & PLUMBING/DCM-75IB\_H

- 115V/60/1
- 20 amp Max Fuse Size
- 1/2" OD copper or equivalent independent water supply
- 3/4" independent drain connection



© HOSHIZAKI AMERICA, INC.

618 Hwy. 74 S., Peachtree City, GA 30269

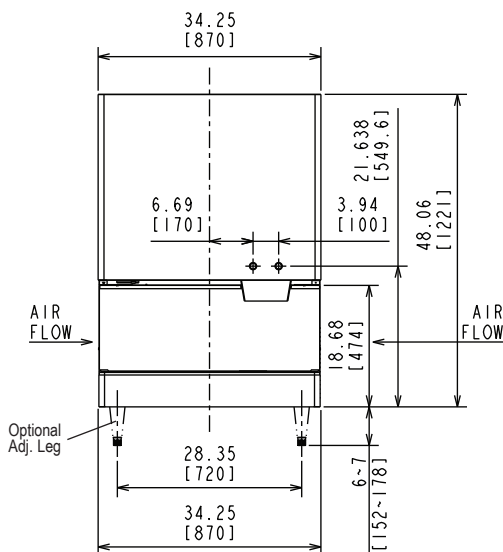

AIR-COOLED UNIT  
FRONT VIEW

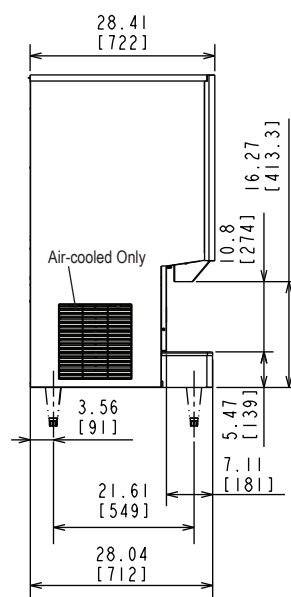

AIR-COOLED UNIT  
SIDE VIEW

ELECTRICAL SUPPLY  
7/8" DIA. OPENING

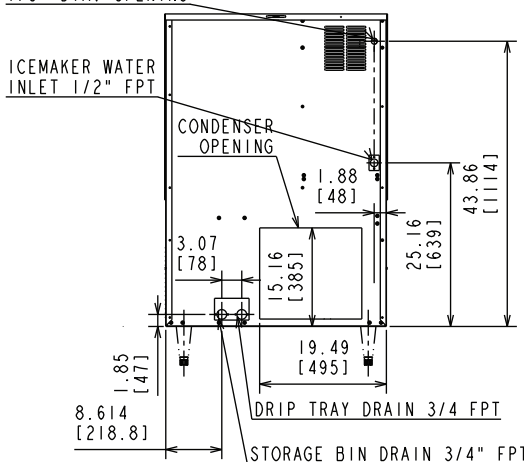

AIR-COOLED UNIT  
BACK VIEW

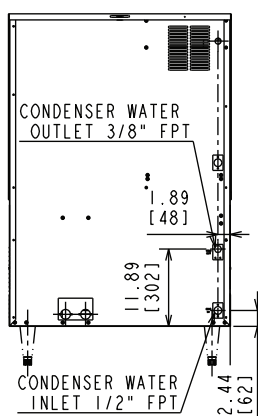

WATER-COOLED UNIT  
BACK VIEW

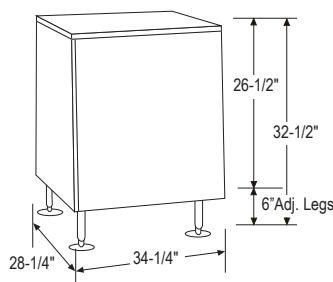

SD-700

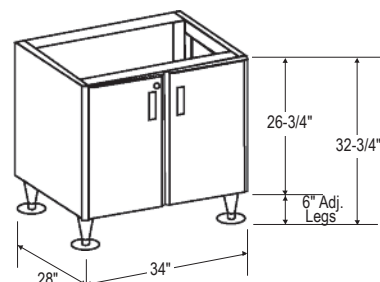

SD-750

## OPERATING LIMITS

• Ambient Temp Range	45 - 100°F
• Water Temp Range	45 - 90°F
• Water Pressure	10 - 113psig
• Voltage Range	104 - 127V

## SERVICE

- Panels easily removed and all components accessible for service.
- Removable/cleanable air filter. (Air-cooled model only)

TEL 1-800-438-6087

FAX 1-800-345-1325

www.hoshizaki.com

Printed in U.S.A.

