

# JWE-2400CUA(-L/-R)-25B

## Jet Wash High Temperature Rack Conveyor Warewasher



### JWE-2400CUA-L-25B

Conveyor Type Warewasher  
Shown

- Industry leading small footprint among rack conveyor warewashers
- Adjustable digital operation panel
- All cleanable parts are removable without tools
- Low energy cost and water conservation
- Tank can be drained without touching wash water
- Front service panel provides easy access to interior
- Exclusive double slit washing nozzles, four on upper and lower
- Two 1hp high flow wash pumps
- Separate .134hp rinse pump
- Open passage height 20.5"
- 240 Racks per hour (Adjustable - 240/200/160)

\* The JWE-2400CUA(-L/-R)-25B is ENERGY STAR qualified - ideal for LEED Certified buildings

JWE-2400CUA(-L/-R)-25B  
8/11

Item # 13279

Project:

Qty:

\*AutoCad available on KCL. Hoshizaki reserves the right to change specifications without notice.

### Dimensions w x d x h

JWE-2400CUA(-L/-R)-25B  
43<sup>5/16</sup> x 27<sup>5/8</sup> x 56<sup>1/8</sup>

### Power Supply (2 Lines)

208 - 230V/60/3ø

### Amperage (Max Load)

116A

Wash Tank - 51.2A

Booster - 63.6A

### Minimum Circuit Ampacity

Wash Tank - 60A

Booster - 70A

### Shipping Weight

584 Lbs.

### Racks per hour

Adjustable - 240/200/160

### Warranty

Valid in United States, Canada, Puerto Rico, and U.S. Territories. Contact factory for warranty in other countries. **Contact the factory for details.**

• **One Year** - Parts & Labor

### © HOSHIZAKI AMERICA, INC.

618 Hwy. 74 S., Peachtree City, GA 30269

TEL 1-800-438-6087

FAX 1-800-345-1325

www.hoshizaki.com



# JWE-2400CUA(-L/-R)-25B

Jet Wash High Temperature Rack Conveyor Warewasher

**DIMENSIONS**  
W x D x H

JWE-2400CUA(-L/-R)-25B  
43<sup>5/16</sup> x 27<sup>5/8</sup> x 56<sup>1/8</sup>



ISO 9001-15014001

Intertek

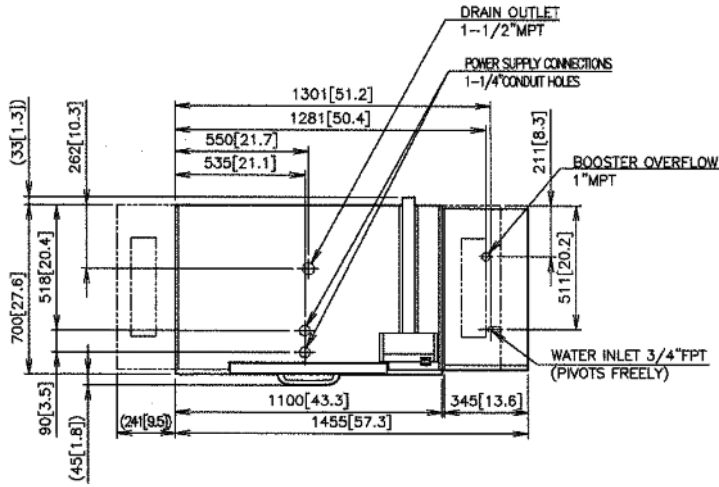

TOP DIMENSIONS  
(-L Model Shown)

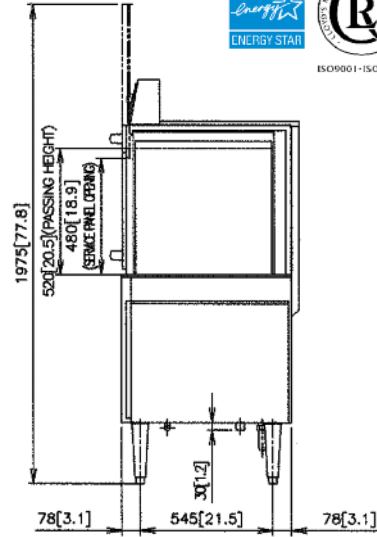

SIDE DIMENSIONS  
(-L Model Shown)

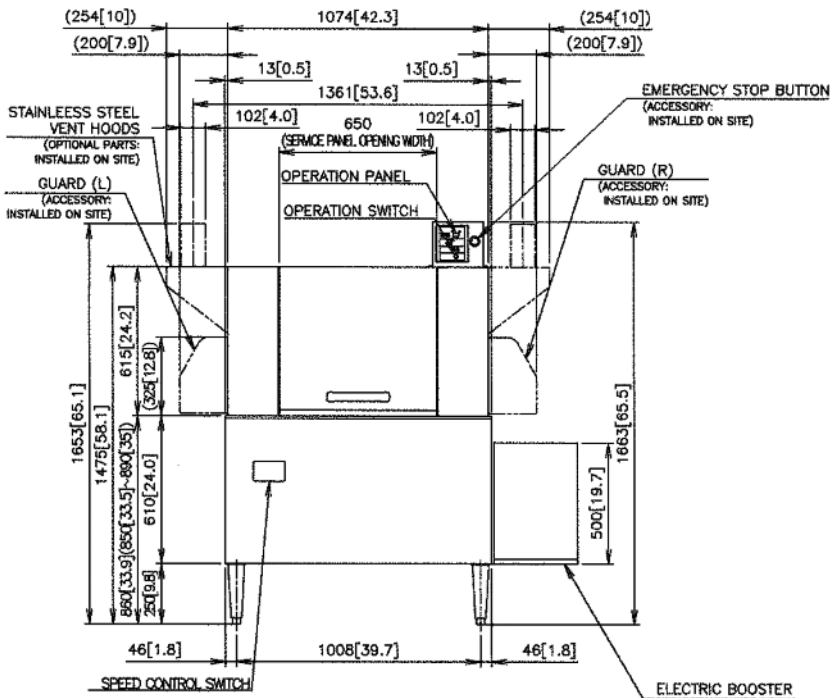

FRONT DIMENSIONS  
(-L Model Shown)

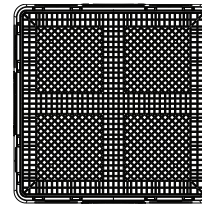

Flatware Rack  
(HS-5040)

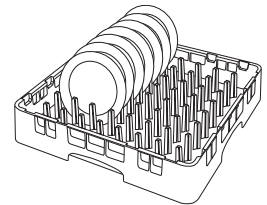

9 x 9 Peg Rack  
(HS-5041)  
Shown

5 x 9 Peg Rack  
(HS-5042)

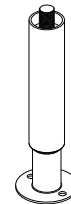

Seismic Leg Kit  
(HS-5026)

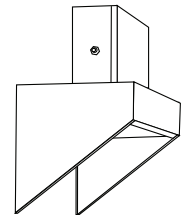

Vent Collar (Set of 2)  
(HS-5025)



Drain Water Tempering Kit  
(HS-5029)

