

KM-151B_H

SELF-CONTAINED CUBER WITH BUILT-IN STORAGE BIN

Item # _____

Project: _____

Qty: _____

*AutoCad available on KCL

KM-151B_H

6/11

Item # 13236

CUBER DIMENSIONS W x D x H

KM-151B_H
23^{3/4} x 28 x 39*
* with 6" legs





KM-151BAH

Air-Cooled
Shown

KM-151BWH

Water-Cooled

- Up to 146 lbs. of ice production per 24 hours
 - Up to 78 lbs. of built-in storage capacity
 - Individual crescent cube
 - Durable stainless steel exterior
 - CycleSaver® Design 
 - EverCheck® alert system 
 - Front in, front out airflow (Air-cooled model only)
 - Stainless steel evaporator
 - Slide in door
 - Removable air filter (Air-cooled model only)
 - Power switch accessible without panel removal
 - Built-in installation possible
 - R-134a Refrigerant
- * The KM-151BAH is ENERGY STAR qualified.

Warranty

Valid in United States, Canada, Puerto Rico, & U.S. Territories. Contact factory for warranty in other countries.

Three Year - Parts & Labor on entire machine.

Five Year - Parts & Labor on: Evaporator.

Five Year - Parts on: Compressor, air-cooled condenser coil.



© HOSHIZAKI AMERICA, INC.

618 Hwy. 74 S., Peachtree City, GA 30269

TEL 1-800-438-6087

FAX 1-800-345-1325

www.hoshizaki.com



SELF-CONTAINED CUBER WITH BUILT-IN STORAGE BIN

DIMENSIONS

W x D x H

KM-151B_H
23^{3/4} x 28 x 39*
*with 6" legs

- Air-cooled
- Water-cooled

AIR-COOLED

Water Temp° F.	50°	70°	90°
Air Temp° F. 70°	146	139	129
Air Temp° F. 80°	140	129	119
Air Temp° F. 90°	139	121	111

WATER-COOLED

Water Temp° F.	50°	70°	90°
Air Temp° F. 70°	146	141	136
Air Temp° F. 80°	142	135	131
Air Temp° F. 90°	141	130	125

UTILITY CONSUMPTION

Model Number	Ice Production Per Cycle		KWH per 100 LBS.	Potable Water Gal. per 100 lbs.	Condenser Water Gal. per 100 lbs.
	Lbs.	Cubes			
KM-151BAH	2.75	130	8.4	17.8	N/A
KM-151BWH	2.75	130	7.3	25.0	140

SPECIFICATIONS

Model Number	Condenser	Amperage	Min. Circuit Ampacity	Shipping Weight
KM-151BAH	Air-Cooled	7.0	15A	150 lbs.
KM-151BWH	Air-Cooled	6.8	15A	154 lbs.

KM CUBE DIMENSIONS

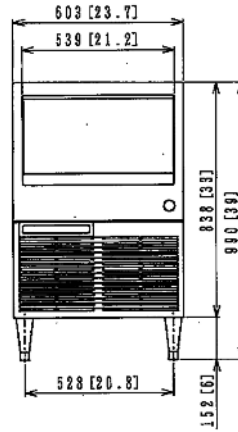
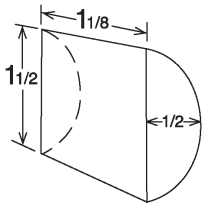

FRONT DIMENSIONS

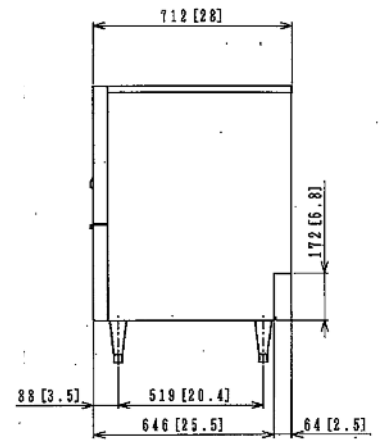

SIDE DIMENSIONS

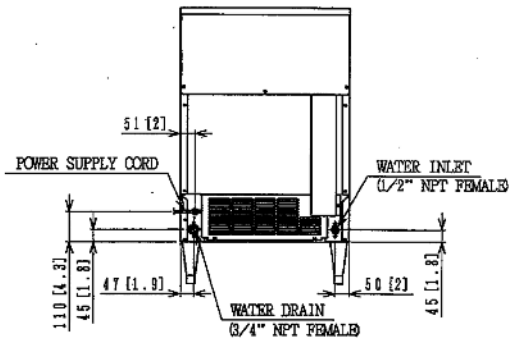

AIR-COOLED UNIT

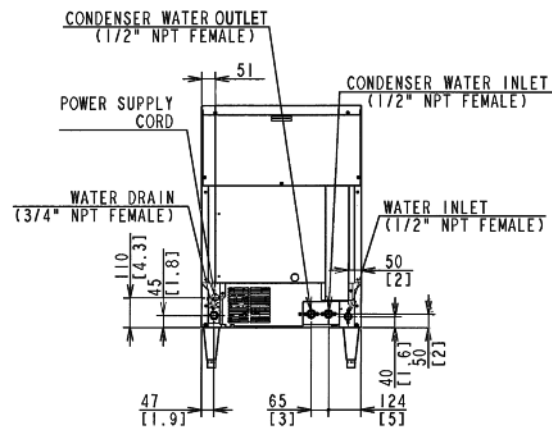

WATER-COOLED UNIT

ELECTRICAL & PLUMBING/KM-151B_H

- 115V/60/1
- 15 amp Max Fuse/HACR Breaker Size
- 3/8" OD copper or equivalent independent potable water supply
- 3/4" independent drain connection
- 1/2" FPT Water Inlet
- 1/2" FPT Condenser Water Outlet (Water-cooled model only)
- 1/2" FPT Condenser Water Inlet (Water-cooled model only)

OPERATING LIMITS

- Ambient Temp Range 45 - 100°F
- Water Temp Range 45 - 90°F
- Water Pressure 10 - 113psig
- Voltage Range 104 - 127V



ISO 9001:2015

© HOSHIZAKI AMERICA, INC.

618 Hwy. 74 S., Peachtree City, GA 30269

TEL 1-800-438-6087

FAX 1-800-345-1325

www.hoshizaki.com

Printed in U.S.A.

