



GEMD520

Optional Stand - GDS5

## The sanitary way to dispense chewable ice and water

- Exclusive Pure Ice® technology ensures protection from odor, bacteria and scaling.
- Touchless dispensing eliminates the risk of cross-contamination.
- Features soft, chewable Pearl Ice®.

## Features

- Up to 523 lbs (237 kg) production and 26 lbs (12 kg) storage capacity.
- Perfect for hospitals, health facilities and offices.
- Easily fills various sizes and types of containers.
- Quiet operation.
- Two-spout operation for increased productivity.

## Options & Accessories

WATER FILTERS			
Ice Machine Model	Manifold		Inline
	System	Replacement	System
GEMD520	N/A	N/A	IF14C/IF18C

STAND			
Model	Finish	Shipping Weight lbs (kg)	Size in. (mm)
GDS5	Stainless Steel	60 (27)	26 x 22.5 x 30 (660 x 572 x 762)

## Ice Maker Warranty

Every Ice-O-Matic ice maker is backed by a warranty that provides both parts and labor coverage.

- Two years **Parts** and **Labor**.
- Five years **Parts** coverage on the compressor.

## Ice Form



PEARL ICE

PEARL ICE DIMENSIONS	
H x Dia. (in.)	1/2 x 3/8
H x Dia. (mm)	12.7 x 9.5

## 24 Hour Ice Production

GEM520A / GEM525A	
Based on Air/Water Temperatures	Air-Cooled 24 Hour Production - lbs (kg)
70°F (21°C)/50°F (10°C)	523 (237)
90°F (32°C)/70°F (21°C)	409 (186)



GEMD520/525 PEARL ICE®/WATER DISPENSER

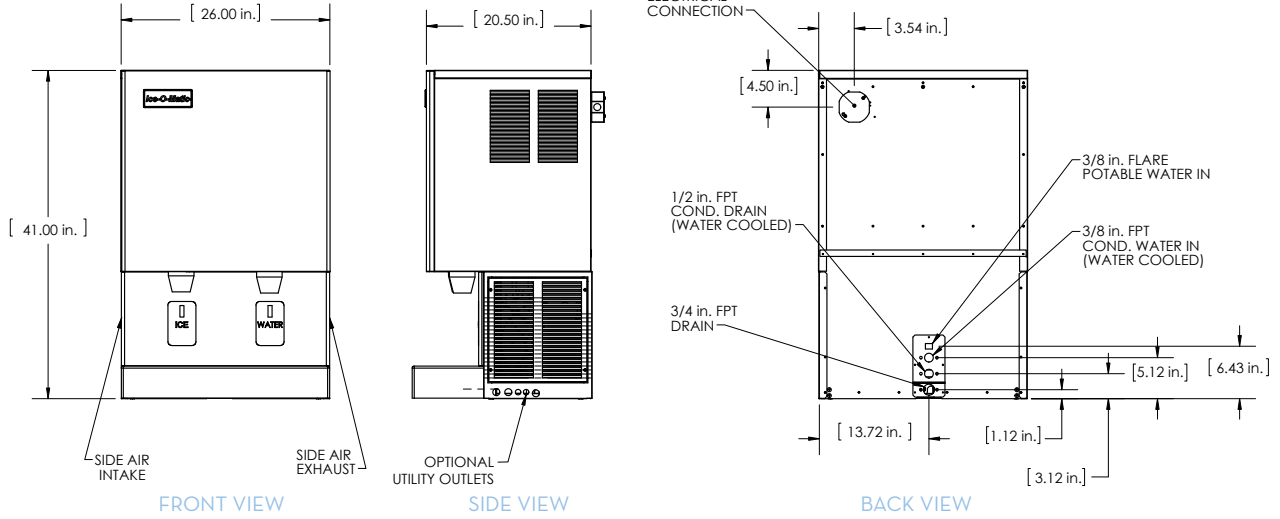

INSTALLATION NOTE: Allow 6" minimum space at sides and back for ventilation and utility connections.

### Operating Requirements

	MINIMUM	MAXIMUM
	<b>50 &amp; 60 Hz</b>	
Ambient Temp. Range Air	50°F (10°C)	100°F (38°C)
Water Temp.	40°F (4.4°C)	
Water Pressure	20 PSIG (1.4 BAR)	120 PSIG (8.3 BAR)
Electrical Voltage	-5%	+10%

### Dimensions

ALL MODELS	
W x D x H (in.)	26 x 20.5 x 41
W x D x H (mm)	660 x 522 x 1,041

### Specifications

Model Number	Cond. Unit	Ice Production per 24 hrs		Water Usage gallons per 100 lbs of Ice		kWh Used per 100 lbs of ice @ 90°F air/70°F water	Voltage Characteristics	Min. Circuit Ampacity	Fuse Size
		70°F air/50°F water lbs (kg)	90°F air/70°F water lbs (kg)	Potable	90°F air/70°F water				
GEMD520A	Air	523 (237)	409 (186)	12	5.4	115/60/1	19.3	25	
GEMD525A	Air	523 (237)	409 (186)	12	4.5	230/50/1	11.5	15	

### Number of Vends (Servings) Per Hour From Full Bin + Recovery = Total Vends

Model Number	Bin Storage lbs/kg	1 Hour Recovery Cap. lbs/kg	2 fl. oz. Bin			4 fl. oz. Bin			6 fl. oz. Bin			8 fl. oz. Bin										
			2 fl. oz. Bin	2 fl. oz. Recovery	Total 2 fl. oz. Vends	4 fl. oz. Bin	4 fl. oz. Recovery	Total 4 fl. oz. Vends	6 fl. oz. Bin	6 fl. oz. Recovery	Total 6 fl. oz. Vends	8 fl. oz. Bin	8 fl. oz. Recovery	Total 8 fl. oz. Vends								
GEMD520A	26/12	22/10	416	+	349	=	765	208	+	175	=	382	139	+	116	=	255	104	+	87	=	191
GEMD525A																						

- NOTES:
- 1lb approx. = 32 fl. oz.
  - Vends per hour are based on 70°F Air/50°F Water
  - Approx. shipping weight = 260 lbs (118 kg)
  - Shipping carton = 30" x 24" x 46" (76 cm x 61 cm x 117 cm)