



**ELECTRIC 50 LB. FRYERS
SPACE SAVER FILTER SYSTEMS**

IMPERIAL®

Model Number

IFSSP250E	IFSSP250EU
IFSSP350E	IFSSP350EU
IFSSP450E	IFSSP450EU
IFSSP550E	IFSSP550EU
IFSSP650E	IFSSP650EU

Add suffix "T" for Electronic Thermostat

Add suffix "C" for Computer Controls

Suffix "E" denotes Immersed Elements

Suffix "EU" denotes Tilt-up Elements



IFSSP250EU

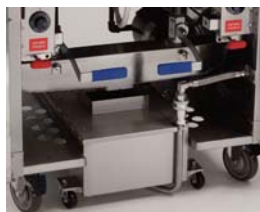

Filter is located under fryers to save valuable space.

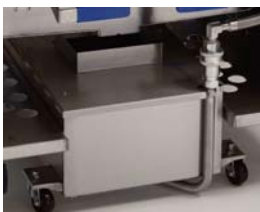

Filter pan is designed for maximum oil return.



5.5 GPM, 1/3 HP roller pump speeds up filtering process.

FILTER PACKAGE CHOICES - Up to six fryers can be battered into one fryer / filter system.

- Available for 50 and 75 lb. (27 and 41 Liters) oil capacity fryers.
- Available with Snap Action Thermostats, Electronic Thermostats or Computer Controls

LOCATED UNDER FRYERS - Filter location under fryers saves valuable space.

- Internally plumbed oil drain and return line.

UNIQUE FILTER PAN DESIGN - Filter pan is designed for maximum oil return.

- Stainless steel construction is easy to clean and has a professional look.
- Positive-latching filter paper holder holds paper in place for optimal filtration.
- Quick disconnect connection offers quick and safe connection of the filtered oil back into the frypots.
- All oil drain and return lines are internally plumbed for convenience and safety.

ROLLER-PUMP - Up to six fryers can be battered into one fryer / filter system.

- 5.5 GPM pump with a 1/3 HP motor speeds up filtering process.
- Can pump oil into a disposal vat up to 20 feet away.

EXTERIOR FEATURES - Continuous cabinet provides a professional look.

- 5" (127 mm) deep continuous stainless steel front landing ledge.
- Stainless steel precision welded frypot.
- Includes casters, joiner strips and filter starter kit.



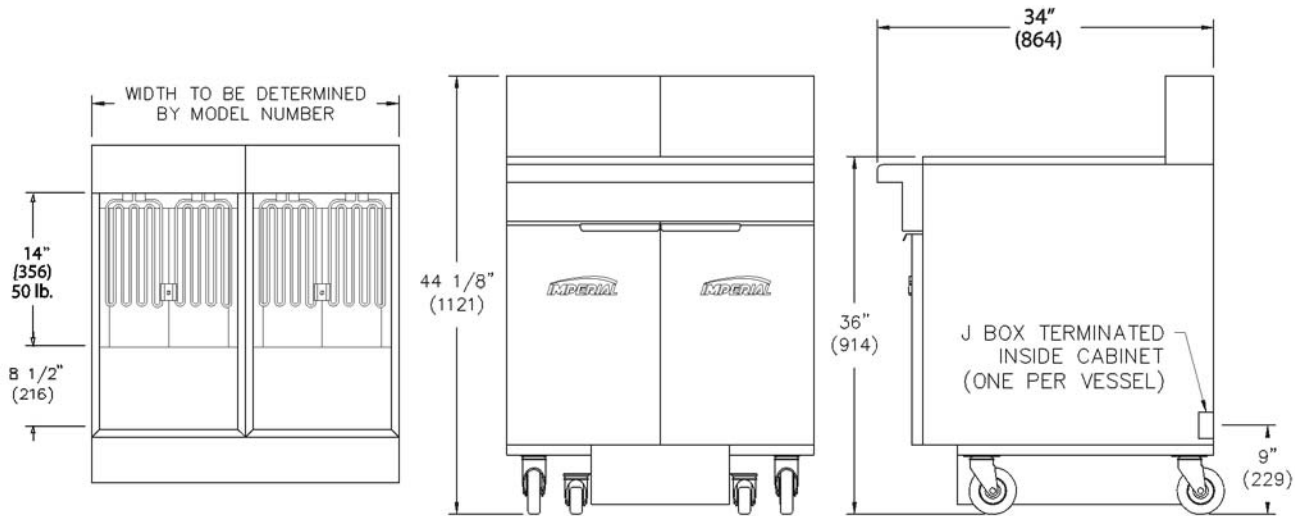

IFSSP250E

**** ONE J BOX PER VESSEL ****

50 LB. ELECTRIC FRYER SPACE SAVER FILTER SYSTEM

MODEL	FRYER OIL CAPACITY	FRYER DEPTH	NUMBER OF FRYERS	SHIP WEIGHT (KG)	LBS
IFSSP250E	50 lbs. (41 L)	30" (762 mm)	2	(252)	556
IFSSP250EU	50 lbs. (41 L)	30" (762 mm)	3	(367)	809
IFSSP350E	50 lbs. (41 L)	30" (762 mm)	4	(482)	1062
IFSSP350EU	50 lbs. (41 L)	30" (762 mm)	5	(596)	1315
IFSSP450E	50 lbs. (41 L)	30" (762 mm)	6	(711)	1568
IFSSP450EU	50 lbs. (41 L)	30" (762 mm)			
IFSSP550E	50 lbs. (41 L)	30" (762 mm)			
IFSSP550EU	50 lbs. (41 L)	30" (762 mm)			
IFSSP650E	50 lbs. (41 L)	30" (762 mm)			
IFSSP650EU	50 lbs. (41 L)	30" (762 mm)			

Measurements in () are metric equivalents.

MODEL	DIMENSIONS	CRATED DIMENSIONS
IFSSP250E	31" w x 34" d x 44-1/8" h	32-1/2" w x 39" d x 49-1/2" h
IFSSP250EU	(787 x 864 x 1121 mm)	(826 x 991 x 1257 mm)
IFSSP350E	46-1/2" w x 34" d x 44-1/8" h	48" w x 39" d x 49-1/2" h
IFSSP350EU	(1181 x 864 x 1121 mm)	(1219 x 991 x 1257 mm)
IFSSP450E	62" w x 34" d x 44-1/8" h	63-1/2" w x 39" d x 49-1/2" h
IFSSP450EU	(1575 x 864 x 1121 mm)	(1613 x 991 x 1257 mm)
IFSSP550E	77-1/2" w x 34" d x 44-1/8" h	79" w x 39" d x 49-1/2" h
IFSSP550EU	(1969 x 864 x 1121 mm)	(2007 x 991 x 1257 mm)
IFSSP650E	93" w x 34" d x 44-1/8" h	94-1/2" w x 39" d x 49-1/2" h
IFSSP650EU	(1969 x 864 x 1121 mm)	(2400 x 991 x 1257 mm)

FILTER ELECTRICAL REQUIREMENT

VOLTS	PHASE	HERTZ	AMPS
115 V	1	60	6.8 amps

6ft. (1829 mm) power cord with 3 prong plug provided

ELECTRICAL REQUIREMENT PER FRYER

MODEL	VOLTS	PHASE	HERTZ	AMPS
50 lbs.	208	3	60	42.38
50 lbs.	240	3	60	36.73
50 lbs.	480*	3	60	18.36

* for export only

CLEARANCE REQUIREMENTS

For use only on non-combustible floors. Legs or casters are required for non-combustible floors. Provide 0" clearance from non-combustible surfaces and 6" (152 mm) from combustible surfaces.

OPTIONS AND ACCESSORIES

- Automatic basket lifts with computerized controls
- Manual controlled basket lifts
- Stainless steel tank cover
- Stainless steel side drain shelf
- Stainless steel side splash
- Manual timer
- Filter paper, 40# thickness, 20 microns
100 sheets per box

