

**HEAVY DUTY RANGES**  
**ADD-A-UNIT**  
**MODULAR MODELS**

**IMPERIAL®**

Model Numbers

IHR-2-12-M    IHR-2-18-M  
 IHR-4-24-M    IHR-1HT-12-M  
 HR-1HT-18-M    IHR-2HT-24-M  
 IHR-G12-M    IHR-G18-M  
 IHR-G24-M    IHR-GT12-M  
 IHR-GT18-M    IHR-GT24-M



35,000 BTU/hr. (10 KW) anti-clogging, removable burner.



Wavy grates raise pan creating more heat transfer than direct metal-to-metal contact.



Grates are flush mount to the front ledge for easy sliding across of the entire top surface.



Hot Tops have even heating across surface.



Griddle Tops have "U" shaped burners directly under plate.



IHR-4-24-M shown with optional backguard with shelf and stainless steel stand with casters

ADD-A-UNITS - Modular/countertop (-M) styles and floor model (-XB) are available.

- 12", 18" and 24" (305, 457, and 610 mm) wide models are available
- Common front landing ledges are available as an option with both styles to create a seamless line-up.

OPEN BURNER - Anti-clogging burner is 21% more efficient than other manufacturers' heavy duty burners.

- 35,000 BTU/hr. (10 KW) output with a 7,000 BTU/hr. low simmer feature.
- One-piece venturi base has no gaskets.
- Venturi slopes down to the burner creating more efficient heating.
- Cast-iron burners remove and separate for cleaning.
- All stainless steel pilot tubing and solid brass top burner valves for a long service life.

GRATES - Wavy grates create more heat transfer. Heat convects in waves for continual heat-to-pan contact.

- Grates measure 12" x 14" (305 x 356 mm) and 18" x 14" (457 x 356 mm) depending on model.
- Cast-iron design features flame shaping center tube for more efficient heat transfer.
- Anti-clogging shield designed into the grate protects the pilot from grease and debris.

HOT TOPS - Heavy duty, highly polished plates provide even heat across entire hot top surface.

- 12" (305 mm) unit has one 12" w x 28" d (305 x 711 mm) plate, 18" has one 18" w x 28" d (457 x 711 mm) plate and 24" (610 mm) unit has two 12" w x 28" d (305 x 711 mm) plates. 12" w x 14" d (305 x 356 mm) is also available.
- "U" shaped burners have 40,000 (12 KW) BTU output. Aeration baffles between burners for quick recovery.
- Burners are located every 12" (305 mm) for 12" and 24" models and every 18" (457 mm) for 18" model. Each burner has one manual control.

GRIDDLE TOPS - Highly polished griddle plate provide even heat across entire surface.

- "U" shaped burners have 30,000 (9 KW) BTU output, located every 12" (305 mm) with one control per burner.
- Aeration baffles between burners for quick recovery.
- Manual or thermostatic (GT36) controls are available.
- 4" (102 mm) wide grease gutter and large grease can with 1 gallon (3.8 L) capacity.



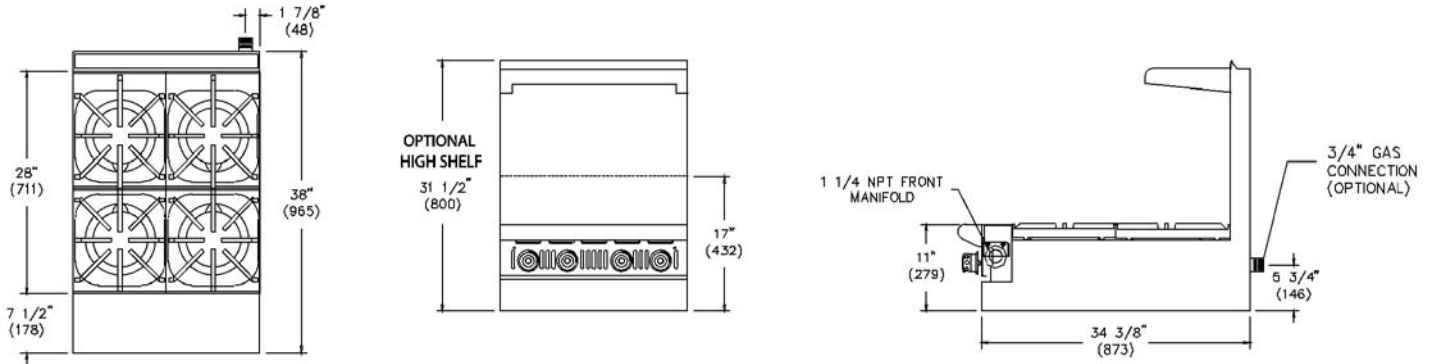

**MODULAR HEAVY DUTY RANGES**

MODEL	WIDTH	GAS OUTPUT		BURNERS	SHIP WEIGHT	
		BTU	(KW)		(KG)	LBS
<b>35,000 BTU (10 KW) OPEN BURNERS</b>						
IHR-2-12-M	12" (305 mm)	70,000	(20 KW)	2	(84)	185
IHR-2-18-M	18" (457 mm)	70,000	(20 KW)	2	(71)	156
IHR-4-24-M	24" (610 mm)	140,000	(41KW)	4	(136)	300
<b>30,000 BTU (10 KW) AND 40,000 BTU (12 KW) HOT TOPS</b>						
IHR-1HT-12-M	12" (305 mm)	30,000	(9 KW)	1	(70)	155
IHR-1HT-18-M	18" (457 mm)	40,000	(12 KW)	1	(94)	206
IHR-2HT-24-M	24" (610 mm)	60,000	(18 KW)	2	(140)	310
<b>30,000 BTU (9 KW) GRIDDLE TOPS</b>						
IHR-G12-M	12" (305 mm)	30,000	(9 KW)	1	(84)	185
IHR-G18-M	18" (457 mm)	30,000	(9 KW)	1	(110)	242
IHR-G24-M	24" (610 mm)	60,000	(18 KW)	2	(138)	305
<b>30,000 BTU (9 KW) GRIDDLE TOPS with THERMOSTAT</b>						
IHR-GT12-M	12" (305 mm)	30,000	(9 KW)	1	(72)	160
IHR-GT18-M	18" (457 mm)	30,000	(9 KW)	1	(110)	242
IHR-GT24-M	24" (610 mm)	60,000	(18 KW)	2	(138)	305

Measurements in ( ) are metric equivalents.

**EXTERIOR**

- Sleek European styling with wide radius ledge and optional high shelf
- Stainless steel front, sides, backguard, shelf and landing ledge
- Enclosed front 1-1/4" (32 mm) manifold
- Large 7" (178 mm) stainless steel landing ledge
- Unique cast aluminum control knobs feature a heat protection grip
- Full width, removable crumb tray for easy cleaning
- One year parts and labor warranty

WIDTH	DIMENSIONS	CRATED DIMENSIONS
12" (305 mm)	12" w x 38" d x 11" h* (305 x 965 x 279 mm)	14-1/2" w x 41" d x 17" h (356 x 1041 x 432 mm)
18" (457 mm)	18" w x 38" d x 11" h* (457 x 965 x 279 mm)	20-1/2" w x 41" d x 17" h (521 x 1041 x 432 mm)
24" (610 mm)	24" w x 38" d x 11" h* (610 x 965 x 279 mm)	26-1/2" w x 41" d x 17" h (673 x 1041 x 432 mm)

\* to cooktop

MANIFOLD PRESSURE	MANIFOLD	
NATURAL GAS	PROPANE GAS	SIZE
5.0" W.C.	10.0" W.C.	1-1/4"

Specify elevation, if over 2,000 ft.

**CLEARANCE REQUIREMENTS**

For use only on non-combustible surfaces. Provide 0" clearance from non-combustible surfaces and 6" (152 mm) from combustible surfaces.

**OPTIONS AND ACCESSORIES**

- Heavy duty stainless steel backguard
- Stainless steel common front landing ledge  
54", 72", 90", 108" (1372, 1829, 2286, 2743 mm)
- Stainless steel common backguard  
54", 72", 90", 108" (1372, 1829, 2286, 2743 mm)
- Stainless steel 10" (245 mm) wok ring, fits over open burner top grate
- 3/4" rear gas connection for single unit connection
- 1-1/4" rear gas connection batteries up to 600,000 BTU (176 KW)
- Gas shut off valve, 3/4" or 1-1/4", N.P.T.
- Gas pressure regulator, 3/4" or 1-1/4", N.P.T.
- Quick disconnect and flexible gas hose, 3/4" 1-1/4", N.P.T.
- Stainless steel equipment stands
- 6" (152 mm) casters for stainless steel stand
- Refrigerated bases 36" and 72" wide (914 and 1829 mm)



H-14

11/13

© 2013 Imperial Commercial Cooking Equipment

Printed in the U.S.A.

1128 Sherborn Street Corona, CA 92879  
 800.343.7790 Ph: 951.281.1830 Fx: 951.281.1879  
[www.imperialrange.com](http://www.imperialrange.com)  
 E-mail: [imperialsales@imperialrange.com](mailto:imperialsales@imperialrange.com)