



CONTROL CENTER MODEL AS-101

WATER SAVING CONTROL CENTERS

WATER AND ENERGY SAVING FEATURES

- The Aqua Saver System acts as an on-demand water-saving system for InSinkErator foodservice disposers
- The AS-101 Control senses the load of the disposer and regulates the amount of water necessary for grinding and non-grinding situations

SPECIFICATIONS

STAINLESS STEEL ENCLOSURE

- NEMA 4
- Waterproof construction
- 18 gallon (68.1 liters) stainless steel
- Easy to clean and keep clean

AUTOMATIC REVERSING CONTROL

- Reverses direction of motor at each startup
- Increases cutting element life and reduces jams

REVERSING DELAY

- Disposer will not reverse while motor is in motion
- Protects motor from burn out from operator misuse

AUTOMATIC DROP OUT SYSTEM

- If a power loss occurs, control will automatically disengage power lines
- Disposer must be restarted

DISCONNECT SWITCH

- Disconnects electrical power beyond switch for service
- Interlock with front cover

SOLID STATE CONTROL

- Operates on 24V

SOLID STATE CONTROL CIRCUIT

- Printed circuit board with control diagnostic/function lights, delay timers and timed run pin and reversing control

POST WATER FLUSH

- Adjustable timer allows water to run automatically for up to 10 minutes, flushing disposer and drain lines after disposer is shut off

TIMED RUN OR CONTINUOUS RUN

- Selected at your discretion, simply by moving the plug-in pin on the printed circuit board
- Timed run shuts off disposer automatically after 10 minutes
- Can be shut off manually any time

SOLENOID VALVE/FLOW CONTROL VALVE

- Two 24V solenoid valves included
- 1 GPM (3.8 LPM) and 7 GPM (26.5 LPM) flow control valves included

WARRANTY

- Standard warranty is 1-year from date of installation. New installations that include a new disposer and new Aqua Saver model AS-101 control panel or AS module, are eligible for an additional 2-year warranty extension (3 years total) for the entire system, including disposer!

VOLTAGE/PHASE AVAILABILITY

Model	Voltage/Hz	Phase
AS101K-1	120V, 50/60 Hz	1 Ph
AS101K-2	208-240V, 50/60 Hz	1 Ph
AS101K-3	208-240V, 50/60 Hz	3 Ph
AS101K-4	380-460V, 50/60 Hz	3 Ph

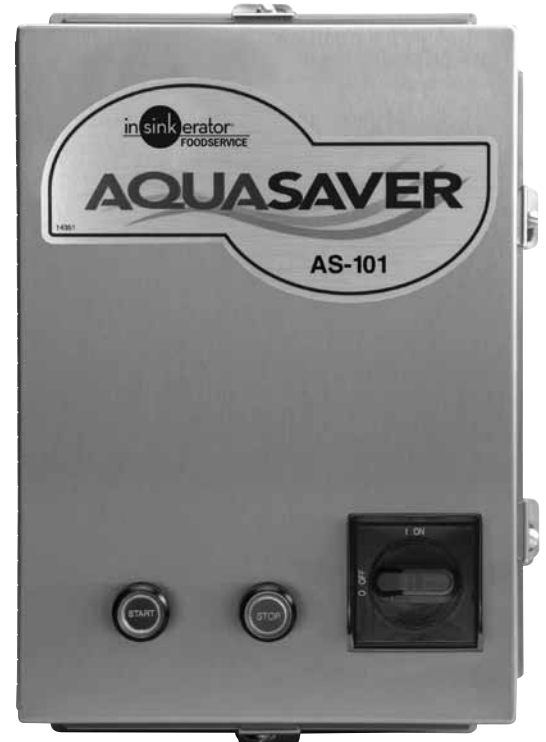

DIMENSIONS

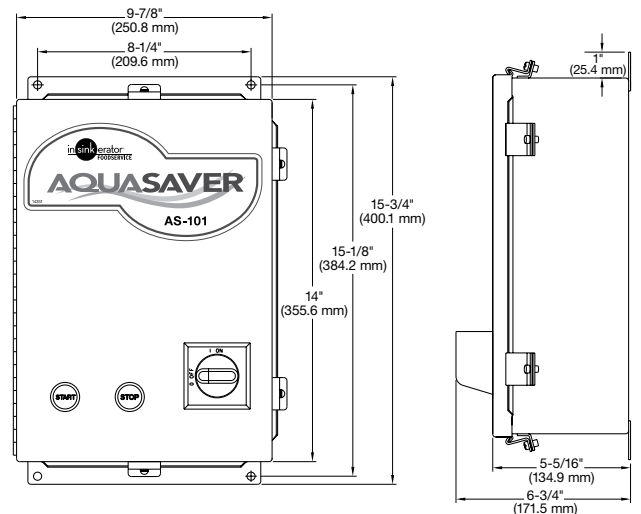

Our products appear on **The KCL CADalog** CD-ROM based CAD Foodservice Symbol Library. More information is available from **Kochman Consultants, Ltd.** at www.kclcad.com.



4700 21st STREET
RACINE, WI 53406
TEL: 800-845-8345
FAX: 262 554-3620

www.insinkerator.com/foodservice



The Emerson logo is a trademark and a service mark of Emerson Electric Co.



TYPICAL TROUGH MOUNT APPLICATION

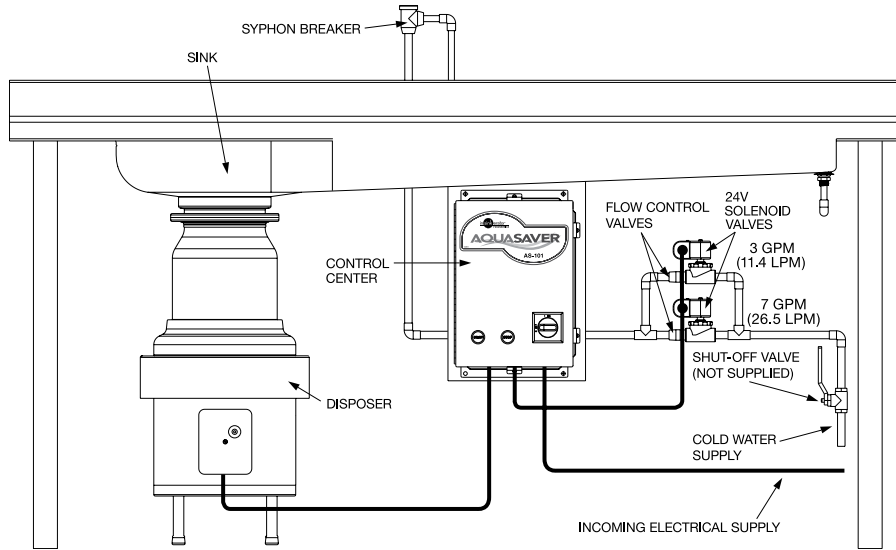

TYPICAL BOWL MOUNT APPLICATION

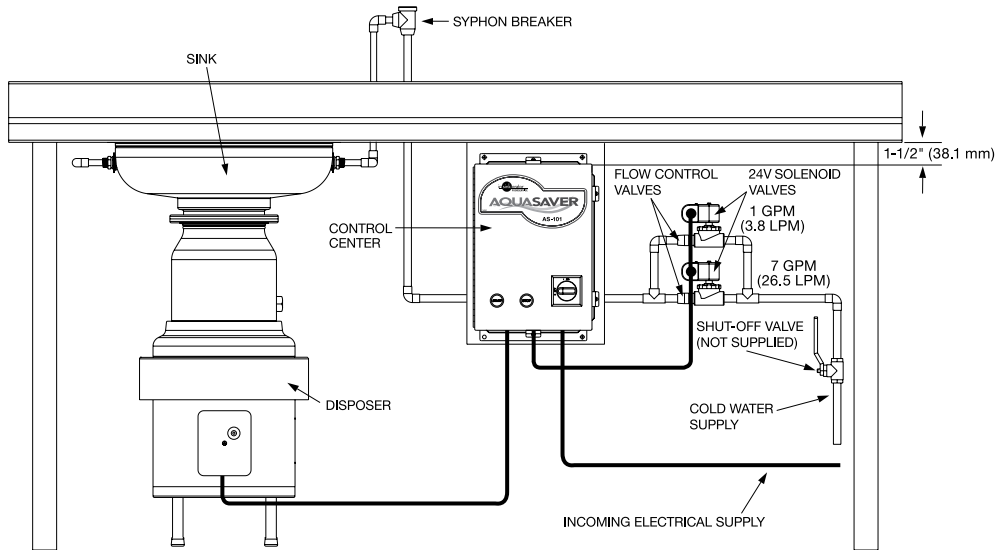

NOTE: The Aqua Saver control center should be mounted 1-1/2" (38.1 mm) back from the front surface of the table.

AS-101 FEATURES

