



Item # _____

Job _____



Metro C5 U-Series Hot or Cold Insulated Transport Cabinet

13.9U

Metro C5 U-Series Hot or Cold Insulated Transport Cabinet

- **Insulation:** 2.5" thick, full perimeter fiberglass insulation for maximum temperature retention during transport
- **Material:** Institutional grade, double wall sheet metal construction. Available in Type 304 stainless steel or .063" Aluminum.
- **Door:** Solid, fully insulated double-panel construction. High strength magnetic flush/twist locking latch to keep door securely closed during transport.
- **Mobility:** Built-in pocket handles on all four corners of cabinet and four 5" swivel casters for improved maneuverability and handling.
- **Capacity:** Two slide systems and generous interior provide flexibility and maximize pan capacity.
 - **Universal Slides:** Hold 18"x26" sheet pans, 12"x20" steam pans, GN pans, or 14"x18" trays. Adjustable on 1 1/2" increments.
 - **Fixed Slides:** Exclusively hold 12"x20" steam pans or GN pans. Fixed 1 1/2" spacing.
- **Dimensions:** C5 U-Series cabinets are available in full height (70.82"), and half height (40.82").

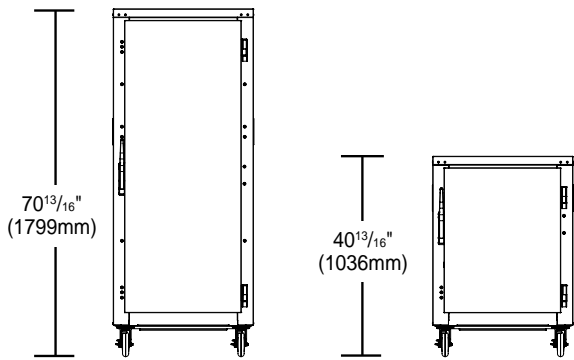

All cabinets are 29.125" (740mm) wide and 32.625" (829mm) deep



InterMetro Industries Corporation
 North Washington Street
 Wilkes-Barre, PA 18705
www.metro.com





Metro C5 U-Series Hot or Cold Insulated Transport Cabinet

Specifications

- **Cabinet Material:** Type 304 stainless steel; 20-gauge polished exterior; 22-gauge interior, or .063" aluminum, brushed exterior, natural interior.
- **Insulation:** Full perimeter, 2.5" thick, high-density fiberglass. R Value=9.9
- **Casters:** Four casters with 5" donut neoprene wheel, double ball bearing swivel, ball bearing axle, nickel plated, two with brake.
- **Doors:** Fully insulated, welded double-panel construction. Type 304 stainless steel or aluminum.
- **Hinges:** Self-closing, lift-off, double hinged, with long-life nylon bearings.
- **Gaskets:** High temperature, cabinet mounted, Santoprene gaskets.
- **Door Latch:** Flush, twist-locking, high-strength magnetic pull latch with lever-action release to keep door securely closed during transport. Chrome plated.
- **Handles:** Four built-in polymer handles.
- **Slides:** Universal wire slides are nickel-chrome plated, adjustable on 1.5" (38mm) increments, and hold 18"x26" (457x660mm) sheet pans, 12"x20" (305x508mm) steam pans, or GN pans. Fixed lip load slides are extruded aluminum, spaced on 1.5" (38mm) increments, and hold 12"x20" (305x508mm) steam pans, or GN pans.
- **Reliability:** Reliability and durability are designed into C5 from the ground up. High-quality components and robust construction provide a long life of service and worry-free use.
- **Slide Capacities:**

Model Number Description

Cabinet Height
9 = Full Height
5 = 1/2 Height

C5U9-SU

Cabinet Material
S = Stainless
N = Aluminum

Slide Type
U = Universal Wire
F = Fixed Lip Load

Models with Accessories or Options

C5U9-SUA

An "A" suffix indicates that accessories need to be factory assembled to the cabinet. Order accessories separately.

Options/Accessories:

- Small Item Shelf (C5-SHELF-S)
- Universal Slide Pair, Chrome (C5-USLIDEPR-C)
- Universal Slide Pair, Stainless (C5-USLIDEPR-S)
- Full Perimeter Bumper (C5-PERMBUMP)
- Rear Push Handle (C5-HANDLE)
- Whiteboard / Clipboard Information Panel (C5-INFOPNL)
- 6" Casters (C5-6CASTER)
- 5" Rear Rigid Casters (C5-5RDGCSTR)
- Factory Left Hand Hinging (DD3768)
- Stainless Steel Universal Slide Upgrades
Full Height (C5-USLIDE-9S)
1/2 Height (C5-USLIDE-5S)

Cabinet Size	Universal Slide Pan Capacity											
	Slide Pairs		Sheet Pans	Steam Pans			65mm Depth		Gastronorm 100mm Depth		150mm Depth	
	Provided	Max	18"x26"	12"x20"x2.5"	12"x20"x4"	12"x20"x6"	2/1	1/1	2/1	1/1	2/1	1/1
Full Height	18	37	18**	36	24	18	18	36	12	24	9	18
1/2 Height	8	17	8**	16	10	8	8	16	5	10	4	8

*Maximum number of slide pairs @ 1.5" spacing. Additional slide pairs ordered separately.
**Standard capacity @ 3" spacing. Increased capacity requires additional slide pairs.

Cabinet Size	Fixed Lip Load Slide Pan Capacity											
	Slide Pairs		Sheet Pans	Steam Pans			65mm Depth		Gastronorm 100mm Depth		150mm Depth	
	Provided	Max	18"x26"	12"x20"x2.5"	12"x20"x4"	12"x20"x6"	2/1	1/1	2/1	1/1	2/1	1/1
Full Height	36	36	N/A	36	24	18	18	36	12	24	9	18
1/2 Height	16	16	N/A	16	10	8	8	16	5	10	4	8

All Metro Catalog Sheets are available on our website: www.metro.com



InterMetro Industries Corporation

North Washington Street • Wilkes-Barre, PA 18705 • 570.825.2741
Fax: 800.638.9263 (East Coast/Canada) • Fax: 800.638.3292 (West Coast)

FOR PRODUCT INFORMATION/CUSTOMER SERVICE:
U.S./Canada/Latin America: 1.800.992.1776 • Europe: +31.76.587.7550
Asia/Pacific: +65.6567.8003 • Middle East/Africa: +971.4.811.8286

Information and specifications are subject to change without notice. Please confirm at time of order

Copyright © 2013 InterMetro Industries Corp.