



Item # _____

Job _____

BANQUET SERVICE CARTS

“Queen Mary”

- **Rugged Construction:** All welded, 16-gauge, 300 Series, stainless steel unitized construction, with 2" (51mm) hemmed edges.
- **Control:** Three-Point-Control Handle is designed with the user in mind. Ergonomically designed for pushing and pulling from both the side and the front. Optional Swing-up handle provides additional control and visibility when moving the cart.
- **Flexible:** Available in 5- and 6-shelf configurations with either flat or ledged shelves.
- **Accessible:** 9¹/₂" (241mm) and 12¹/₄" (311mm) shelf spacing provides maximum access and storage on shelves.
- **Maneuverability:** Large 8" (203mm) casters provide optimal rollability. Optional swivel-lock caster system allows the cart to be moved in-and-out-of-line without dragging. Rigid casters can be made to swivel for movement in tight spaces and automatically switch back to rigid when needed for moving down halls.
- **Versatile:** Can be used for banquet service, bussing, general back-of-the-house transportation, and mobile storage.
- **Durable:** Wraparound bumper is non-marking and will protect the cart, wall, and equipment from damage.



MQ-609L
(Shown with optional swing-up handle)



Banquet Service Carts — “Queen Mary”



InterMetro Industries Corporation
North Washington Street
Wilkes-Barre, PA 18705
www.metro.com



12.50



BANQUET SERVICE CARTS

Specifications

Construction: Welded, hemmed, stainless steel construction.

Material: Polished, 300 Series stainless steel.

Shelves: 16-gauge stainless steel with 2" (51mm) hemmed edge. Each shelf is 24" (610mm) wide x 57" (1447mm) long (usable space).

Uprights: 11-gauge stainless steel.

Casters: Four 8" (203mm) polyurethane casters. Two rigid, two swivel with brakes.

Handle: Unique Three-Point-Control Handle. 1" (25mm) diameter stainless steel construction.

Bumper: Non-marking, solid vinyl bumper mounted to 1/8" (3.1mm) thick aluminum support channel with closed corners.

Load Rating: 200 lbs. (91kg) equally distributed per shelf; 1,000 lbs. (455kg) per cart.

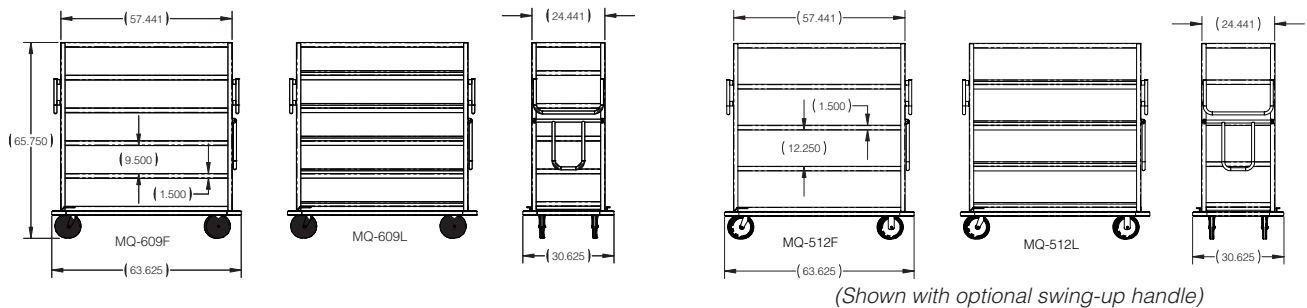

Dimensions

Cat. No.	Description	Length/Width/Height		Approx. Pkd. Wt.	
		(in.)	(mm)	(lbs.)	(kg)
MQ-512F	Five Shelves — Flat	63.625x30.625x65.75	1616x778x1670	300	136
MQ-609F	Six Shelves — Flat	63.625x30.625x65.75	1616x778x1670	325	147
MQ-512L	Five Shelves — Lugged*	63.625x30.625x65.75	1616x778x1670	300	136
MQ-609L	Six Shelves — Lugged*	63.625x30.625x65.75	1616x778x1670	325	147

*Top shelf is flat.
 For swivel lock caster upgrade, add "-SL" to the part number. Example: MQ-609F-SL.
 For swing-up handle, add "-H" to the part number. Example: MQ-609F-H.
 Add "-SL-H" for both.

All Metro Catalog Sheets are available on our Web Site: www.metro.com

Banquet Service Carts — "Queen Mary"



InterMetro Industries Corporation
 North Washington Street, Wilkes-Barre, PA 18705
 Phone: 570-825-2741 • Fax: 570-825-2852
 For Product Information Call: 1-800-433-2232

L02-062
 Printed in U.S.A. 5/08
 Information and specifications are subject to change without notice. Please confirm at time of order.
 Copyright © 2008 InterMetro Industries Corp.