



STANDARD FEATURES:

- Double Chamber Gas Pasta Cooker in 18/10 stainless steel.
- 304 and 316 series stainless steel construction.
- 12 gallon water capacity per tank chamber.
- Triple fiberglass insulation on all sides.
- Seamless stainless steel baskets with specially designed perforated holes.
- Multiple basket size configurations.
- Specially designed burner creates a water current flow lifting and carrying starch out.
- Automatic pilot.
- Automatic On/Off safety switch mechanism.
- Top mount water faucet for continuous clean water flow.
- 60,000 BTU per chamber burner.
- Adjustable legs.
- A.G.A. and NSF approved.



Intertek
ANSI U.L. 197
CSA 222
ANSI Z83.11b-2009
CSA 1.8b-2009



Intertek
ANSI/NSF STD 4

Rosito Bisani

An ongoing program of product improvement may require us to change specifications without notice.
Revised July 2012

Rosito Bisani Imports, Inc.

530 S. Henderson Rd.
Suite F
King of Prussia, PA 19406

sales@rosito-bisani.com or visit rosito-bisani.com

Toll Free (800) 215.8563

Tel (610) 265 5950

Fax (888) 576 8524

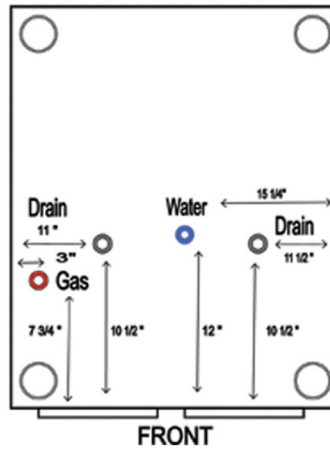
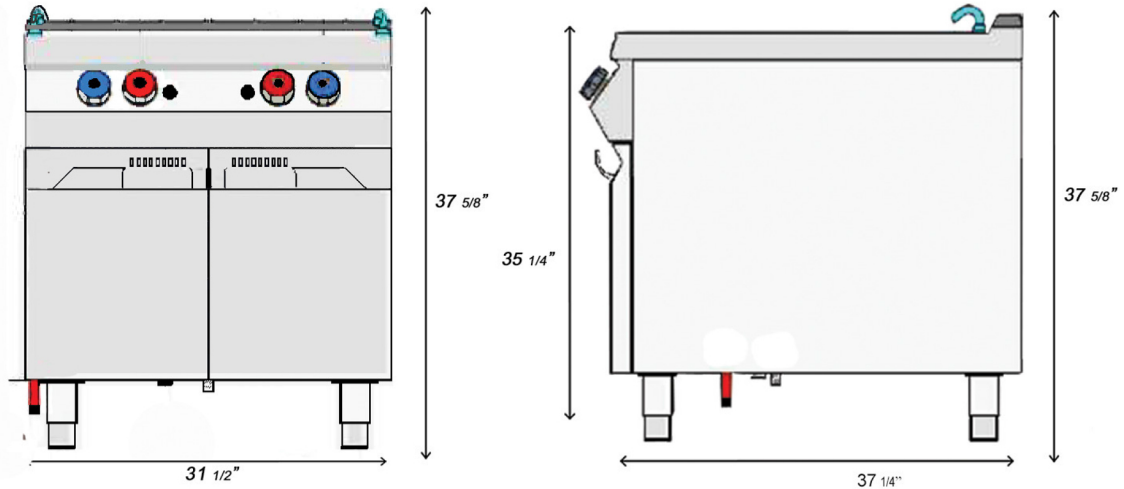

MODEL	UNIT DIMENSION			TANK DIMENSION			CAP. (GAL.)	WT. SHIP.WT	K.W.	V.	PH.	HZ	AMPS	H ₂ O	GAS	DRAIN	BTU	WATER COLUMN
	W	D	H	W	D	H												
CPG 2 (GAS)	31 1/2" X 37 1/4" X 37 5/8"	20	11	12	24	280	X	X	X	X	X	3/8"	3/8"	1 1/4"	12,000	4 1/2"		
																	300	
CPE 2 (ELECTRIC)	31 1/2" X 37 1/4" X 37 5/8"	20	11	12	24	280	15	220	3	60	77	3/8"	X	1 1/4"	X	X		
						300												



Intertek
ANSI U.L. 197
CSA 222
ANSI Z83.11b-2009
CSA 1.8b-2009



Intertek
ANSI/NSF STD 4

Rosito Bisani

An ongoing program of product improvement may require us to change specifications without notice.
Revised July 2012

Rosito Bisani Imports, Inc.

530 S. Henderson Rd.
Suite F
King of Prussia, PA 19406

sales@rosito-bisani.com or visit rosito-bisani.com

Toll Free (800) 215.8563

Tel (610) 265 5950

Fax (888) 576 8524