



"DNS" Maple Top Tables with RISERS

w/ 1 3/4" thick Hard Rock Maple Top
w/ Galvanized Base and Undershef



AUTOQUOTES



1 3/4" MAPLE TOP w/ UNDERSHELF					
24"WIDE	Qty	30"WIDE	Qty	36"WIDE	Qty
DNS01		DNS07		DNS13	
DNS02		DNS08		DNS14	
DNS03		DNS09		DNS15	
DNS04		DNS10		DNS16	
DNS05		DNS11		DNS17	
DNS05A		DNS11A		DNS17A	
DNS06		DNS12		DNS18	

FEATURES:

- * 1 3/4" Thick Hard Rock Maple Top, style "SB" with 4" Coved Riser on Back and Both Ends
- * Maple top with Oil Finished with optional Varnique Finish
- * Galvanized base and undershef,
- * Undershef is secured in a fixed position, 12" above floor
- * Adjustable bullet feet
- * Shipped knocked-down, easy - to - assemble
- * Optional drawers, casters, pot racks, etc. available
- * All models are approved by the National Sanitation Foundation

MATERIAL:

- Top: Laminated Hard Rock Maple
- Shelf: 18 gauge Galvanized Steel
- ** 6 ft. table only, 16 gauge galvanized steel
- Legs: 16 gauge Galvanized Steel
- Gussets: Galvanized Steel
- Feet: 1" adjustable galvanized bullet feet

OPTIONAL ACCESSORIES

	MODEL #	Qty
DRAWER		
DRAWER LOCK		
ADJUSTABLE SHELF		
CASTERS		
OVERSHELVES		
POT RACK		

John Boos & Co

3601 S. Banker Street - Effingham, IL 62401
 Phone: 217-347-7701 - Fax: 217-347-7705
 Email: sales@johnboos.com - Web-site: www. johnboos.com

DETAILED SPECIFICATIONS

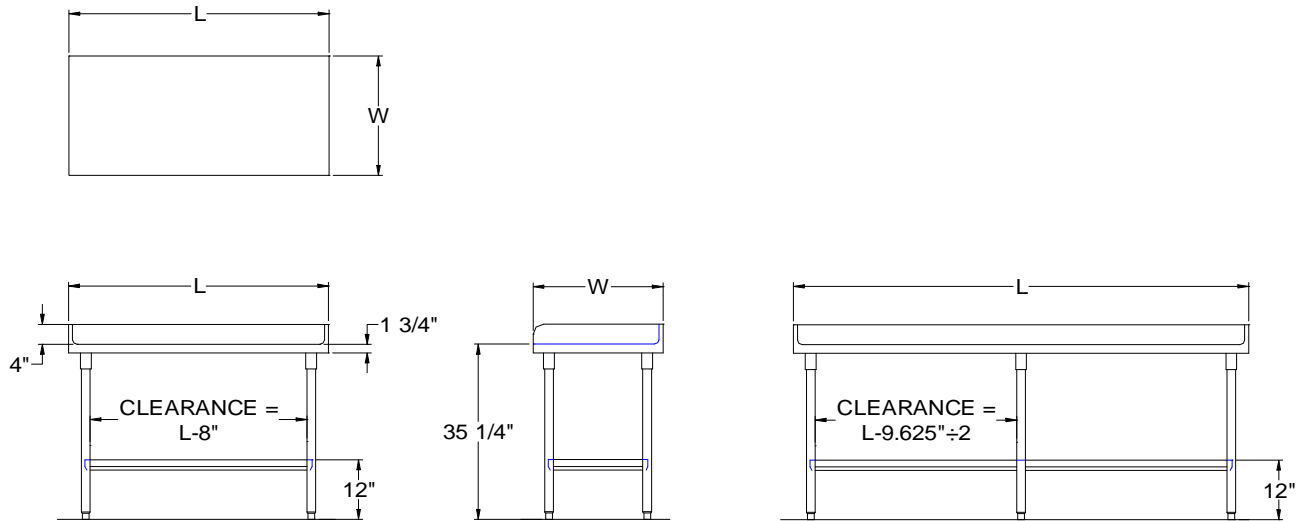

All units ship unassembled for reduced shipping cost.
 Units 7 ft. and larger are furnished with six legs.
 All dimensions are typical.
 Tolerance +/- .500".

Finished size of undershelf.
 Shelf length = length minus 4.875"
 Shelf width = width minus 4.25"

1-3/4" MAPLE TOP & UNDERSHELF

L	24" WIDE	WT.	30" WIDE	WT.	36" WIDE	WT.
48	DNS01	126	DNS07	149	DNS13	172
60	DNS02	149	DNS08	117	DNS14	205
72	DNS03	172	DNS09	205	DNS15	237
84	DNS04	194	DNS10	232	DNS16	269
96	DNS05	218	DNS11	260	DNS17	301
108	DNS05A	245	DNS11A	292	DNS17A	338
120	DNS06	272	DNS12	324	DNS18	375

John Boos & Co

3601 S. Banker Street - Effingham, IL 62401 Phone: 217-347-7701 - Fax: 217-347-7705
 Email: sales@johnboos.com - Web-site: www.johnboos.com



July 2013

John Boos is constantly engaged in a program of improving products and therefore reserves the right to change specification without prior notice