

Dimensional Data (inches and [mm]) are Subject to Manufacturing Tolerances and Change Without Notice

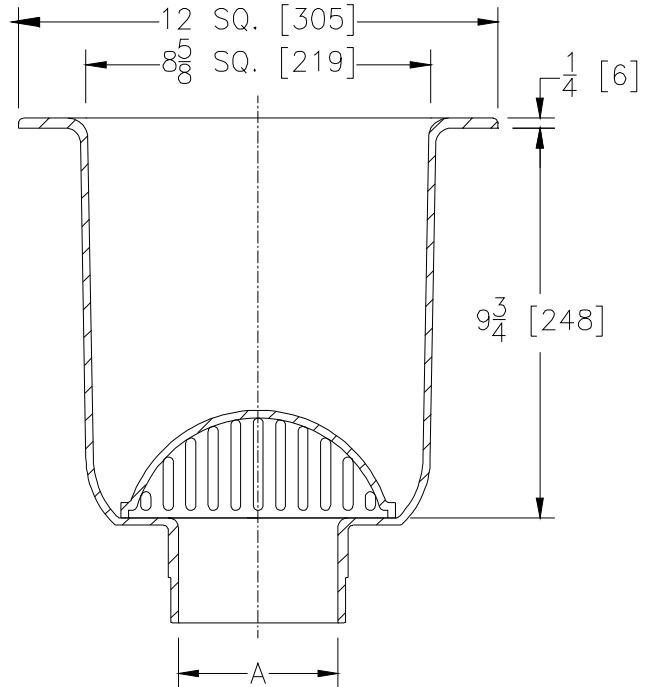

Product	'A' Connections
__ FD2377-NH2	2 [51] No-Hub
__ FD2377-NH3	3 [76] No-Hub
__ FD2377-NH4	4 [102] No-Hub

FD2377 12x12 [305x305] A.R.E. Floor Sink 10 [254] Sump Depth

Recommended for sanitary installations. It consists of a cast iron body with a white acid-resisting porcelain enamel interior coating, and an ABS anti-splash dome strainer.

OPTIONS:

- ___ -F Full Grate
- ___ -H 1/2 Grate
- ___ -T 3/4 Grate
- ___ -Y Sediment Bucket

Typical Installation

