



Job _____

Item _____

Ice & Water Dispenser

Model Number

DISP-1000-IND

ISE Advantage

Ice Storage, Dispensing & Transportation Equipment



Features

- Automatic ice dispensing
- Two water spigot stations
- One water inlet connection for both spigots and ice maker
- Fully welded stainless steel auger
- Fully welded stainless steel agitator(s)
- 1/2HP motor(s) with torque overload & recovery
- 2400 volt, single phase, 15 amp power
- Foot pedal activated
- Sturdy bin structure
- Adjustable bag shelf
- Adjustable feet
- Minimal silicone
- First in first out ice
- Factory installed drain
- Fully welded base frame
- All systems are shipped fully assembled
- FOB origin on all freight unless pre-approved

Options

- Timed dispensing
- Timed agitation
- Bag blower
- Wicket assembly
- Power conversion
- Private labeling
- Coved corners
- Security package
- Custom designs / applications

Applications

- Factories/Manufacturing
- Mining
- Farming
- Sports Venues
- Golf Courses
- Public Works
- Marinas



ACTIVELY SUPPORTING



Toll Free Phone: 1-800-346-3246

Local Phone: (303) 761-1615

Fax: (303) 789-1741

E-mail: dhall@kloppenberg.com

www.kloppenberg.com

4/3/2015

Printed in U.S.A.

Model Number
DISP-1000-IND

Ice & Water Dispenser

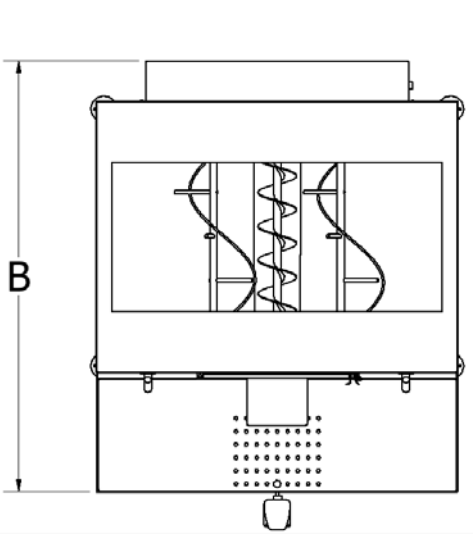

TOP VIEW

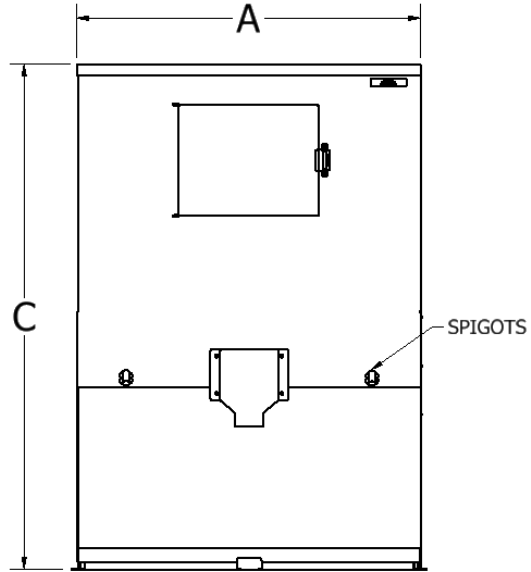

FRONT VIEW

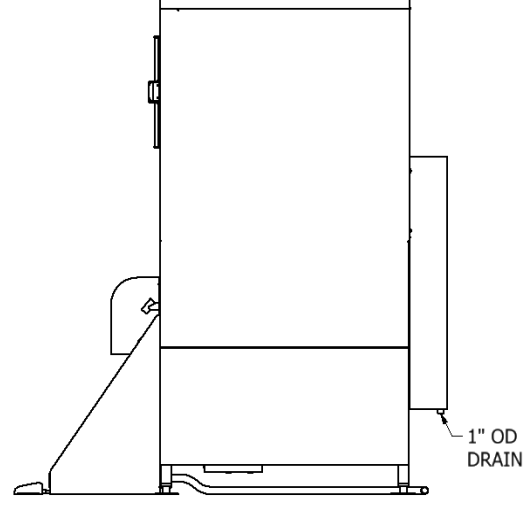

SIDE VIEW

Contact factory for details on CAD Symbols Library availability on this product

Model Number	Capacity lbs (kg)	A-Width in (mm)	B-Depth in (mm)	C-Height in (mm)	Minimum Door Clearance	Ship Weight lbs (kg)
DISP-1000-IND	1,078 (489)	48 (1,219)	58 (1,473)	73.5 (1,867)	50 (1,270)	630 (286)

ELECTRICAL CONNECTION:



OPTIONS:

- Stainless steel or poly liner
- Bullet or flanged feet

ACCESSORIES:

- Bag sealers
- Scoops
- Paddles
- Carts
- Totes
- Igloos

Toll Free Phone: 1-800-346-3246
Local Phone: (303) 761-1615