



## 23 CU. FT. REACH-IN REFRIGERATOR

## KCBM23R



**Dynamic Condenser** improves performance in high temperature environments

**Automatic Defrost Cooling System** provides worry-free performance

**1/3 HP Compressor**

**Stainless Steel Exterior & Interior**

**Digital Controls**

**External Temperature Display**

**Removable Door Gaskets**

**Adjustable Shelves**

**Self-Closing Doors** with 90-degree stay-open feature

**Lock & Key** protects the contents of the unit

**Heavy Duty Casters**



### TECHNICAL SPECIFICATIONS

MODEL	KCBM23R
Product Line	Refrigerator
Capacity (Cu. Ft.)	23.0
Condenser Type	Dynamic
Automatic Defrost Cooling System	Yes
Compressor Horsepower	1/3
Exterior Finish	Stainless Steel
Interior Finish	Stainless Steel
Shelves (Number/Type)	3/Vinyl-Coated Steel
Controls	Digital
Temperature Display Location	External
Temperature Range	32 to 50°F
Voltage Rating	115V/60Hz
Run Amps	7.4
Plug Type	NEMA 5-15P
Shipping Weight (Lbs.)	350
Warranty	2 Year / 5 Year

#### Digital Temperature Display

Quick set digital display for easy monitoring.

#### Stainless Steel Interior

Durable and easy to clean for daily commercial use.

#### Vinyl Heavy Duty Adjustable Shelves

Shelves that are easy to handle and keep clean.





# 23 CU. FT. REACH-IN REFRIGERATOR

## KCBM23R

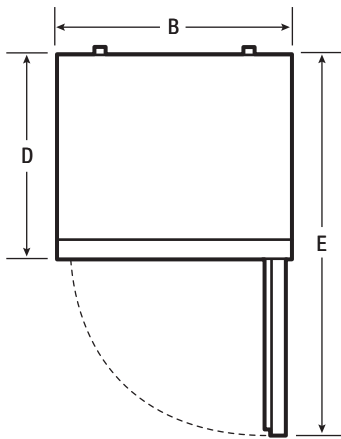

Top View

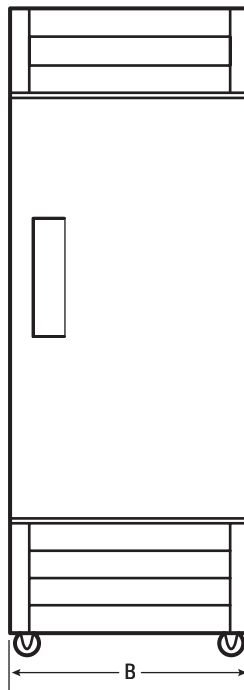

Front View

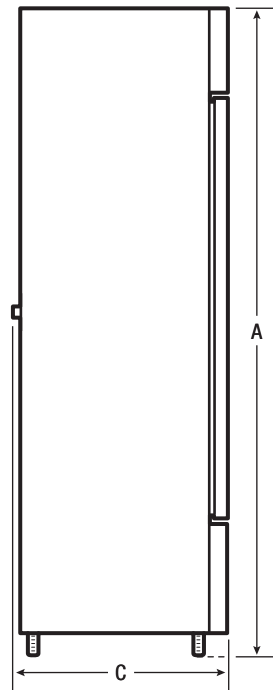

Side View



Plug Type (NEMA)  
5-15P

### EXTERIOR DIMENSIONS

Height <b>A</b> (Including Casters)	82"
Width <b>B</b>	29"
Overall Depth (Including Door & Handle) <b>C</b>	34"
Cabinet Depth <b>D</b>	32"
Depth (with Door 90° Open) <b>E</b>	58-1/2"

### CERTIFICATIONS AND APPROVALS

ENERGY STAR® Qualified	Yes
Safety Certification	ETL
Sanitation Certification	ETL

### ACCESSORIES

Shelf	5304486092
Shelf Rail	5304486093
Door Lock	5304487079
Key	5304487080



USA • 10200 David Taylor Drive • Charlotte, NC 28262 • 1-866-738-1640 • kelvinator.com • KelvinatorCommercial.USA@electrolux.com  
CANADA • 5855 Terry Fox Way • Mississauga, ON L5V 3E4

KCBM23R 06/12

© 2012 Electrolux Home Products, Inc.

High standards of quality at Electrolux Home Products, Inc. mean we are constantly working to improve our products. We reserve the right to change specifications or discontinue models without notice.