



13.6 CU. FT. SCHOOL MILK COOLER

KCMC34RW



- 1/5 HP Compressor**
- Stainless Steel Interior**
- Electronic Controls**
- External Temperature Display**
- Removable Door Gasket**
- Locking Lid & Key** protect the contents of the unit
- Heavy Duty Casters**
- Interior Drain**



TECHNICAL SPECIFICATIONS

MODEL	KCMC34RW
Product Line	Refrigerator
Capacity (Cu. Ft.)	13.6
Condenser Type	Fin & Tube
Automatic Defrost Cooling System	Yes
Compressor Horsepower	1/5
Exterior Finish	Painted Steel
Interior Finish	Stainless Steel (304)
Shelves (Number/Type)	1/Vinyl-Coated Steel
Control	Electronic
Temperature Display Location	Back Side
Temperature Range	32 to 50°F
Voltage Rating	115V/60Hz
Run Amps	6.4
Plug Type	NEMA 5-15P
Shipping Weight (Lbs.)	253
Warranty	3 Year/5 Year

Electronic Digital Temperature Control

Quick set digital control and display for easy monitoring.

Stainless Steel Interior

Durable and easy to clean for daily commercial use.

Heavy-Duty, Locking Casters

Keeps unit in place but allows position adjusting.





13.6 CU. FT. SCHOOL MILK COOLER

KCMC34RW

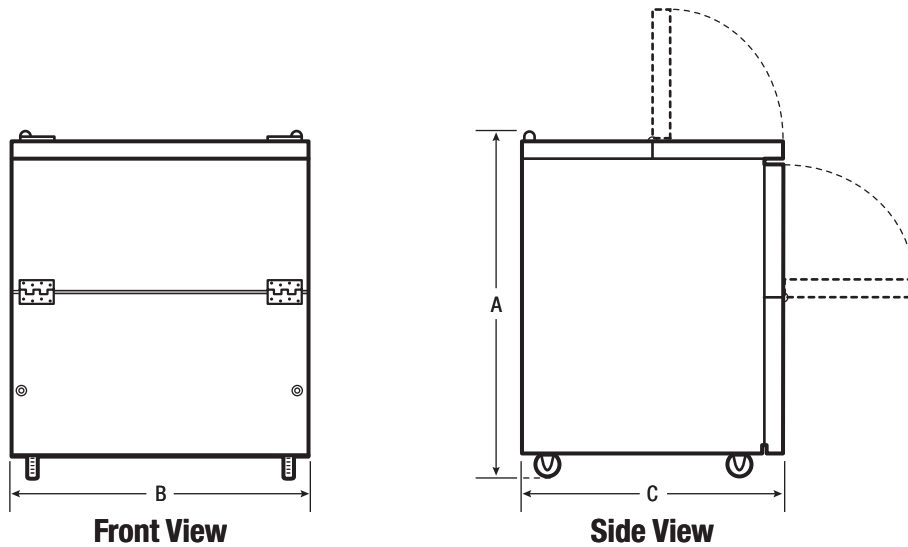

Plug Type (NEMA)
5-15P

EXTERIOR DIMENSIONS

Height A (Including Casters)	42"
Width B	34"
Cabinet Depth C	34"

CERTIFICATIONS AND APPROVALS

Safety Certification	ETL
Sanitation Certification	ETL



USA • 10200 David Taylor Drive • Charlotte, NC 28262 • 1-866-738-1640 • kelvinator.com
CANADA • 5855 Terry Fox Way • Mississauga, ON L5V 3E4

KCMC34R 07/14

© 2014 Electrolux Home Products, Inc.

High standards of quality at Electrolux Home Products, Inc. mean we are constantly working to improve our products. We reserve the right to change specifications or discontinue models without notice.