

ITEM NO. _____
PROJECT _____
LOCATION _____
DATE _____ QTY. _____



KSCTM7-B

KSCTM7-B SERIES

Countertop Merchandiser



MODEL

KSCTM7-B

FEATURES

CONSTRUCTION

- Standard LED lighting
- Black painted steel exterior
- White painted interior
- Foamed-in-place with low ODP polyurethane insulation
- Epoxy-coated floor rack
- Two epoxy coated shelves with front stops
- Four adjustable levelers

DOORS

- Magnetic gaskets
- Self-closing hinges
- Recessed handle
- Reversible door (right hinge standard)

REFRIGERATION

- Self-contained refrigeration system
- ENERGY STAR qualified, may be eligible for rebate programs
- Refrigerant: R-134a
- Operating temperature: 38°F (3°C)

WARRANTY

- Standard limited one year parts and labor
- Additional four year coverage on compressor part



KSCTM7-B SERIES COUNTERTOP MERCHANDISER

TECHNICAL SPECIFICATIONS

MODEL	DIMENSIONS (in.)			DIMENSIONS (mm)			VOLTS	AMPS	UNIT H.P.	NO. OF SHELVES	CAPACITY CU. FT. (LESS STEP)	CAN CAPACITY (12 OZ.)	SHIP CU. FT.	SHIP WT. (LB/KG)
	L	D	H	L	D	H								
KSCTM7-B	20 ³ / ₈	24 ³ / ₈	36 ¹ / ₂	518	619	927	115	2.1	1/10	2	6.35	168	13.3	130/59

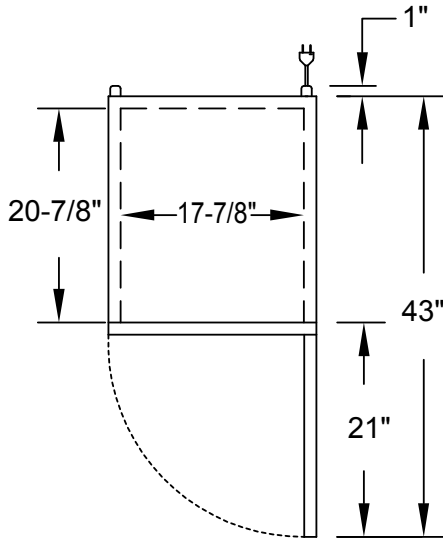

PLAN VIEW

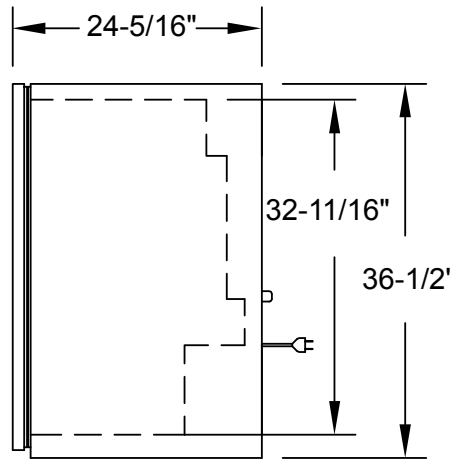

SIDE VIEW

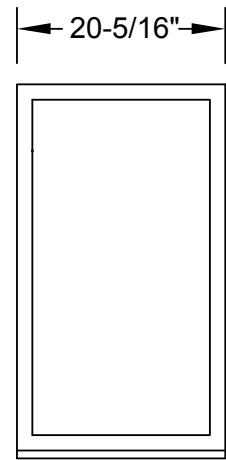

ELEVATION VIEW

LISTINGS



- Meets Canadian energy efficiency regulations
- California Energy Commission listed

HOOKUP

All models: Via plug in, flexible three wire 14/3 cord with molded plug.

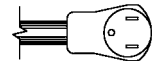

NEMA 5-15P

BID SPECIFICATIONS

Item no. KSCTM7-B. Provide _____ Countertop Merchandiser(s), Kool Star model no. KSCTM7-B.

Merchandiser standard finish will be black painted exterior and white painted interior.

Merchandiser will be equipped with standard LED lighting, an epoxy-coated floor rack and two epoxy-coated shelves with front stops.

The door will feature magnetic gasket, self-closing hinges and a recessed handle. Door will also be reversible with right hand hinging standard.

The refrigeration system will be self-contained and will use R-134a refrigerant. The operating temperature will be 38°F (3°C).

Merchandiser to have standard limited three year parts and labor with additional two

year coverage on compressor part.

Merchandiser to be ENERGY STAR® qualified and ETL listed in the U.S. and Canada and ETL Sanitation listed. Additionally, it will meet Canadian energy efficiency regulations and be California Energy Commission listed.

NOTE: Cabinet designed for optimum performance in air-conditioned area at 75°F ambient and 55% relative humidity. All specifications subject to change without notice.