

ITEM NO. _____
 PROJECT _____
 LOCATION _____
 DATE _____ QTY. _____



KSGFP-HG SERIES

Bottom Mounted
 Swinging Glass Door
 Freezer Merchandisers
 With Lighted Sign

MODELS

- KSGFP23-HG
- KSGFP27-HG
- KSGFP48-HG
- KSGFP74-HG

FEATURES

CONSTRUCTION

- Standard interior LED lighting
- Standard programmable electronic controller featuring:
 - Audible and visual alarm
 - Eliminates room thermostat, defrost termination/fan delay control, defrost timer and digital thermometer or other temperature indicator
- 24 gauge painted textured galvanized steel interior and exterior
- Standard exterior finishes: Black or white
- Standard interior finish: White with stainless steel floor
- Top backlit graphic panel (standard blank sign applied without graphics)
- 1³/₄" thick state-of-the-art, foamed-in-place "zero ODP" polyurethane insulation provides high R-value
- Adjustable legs for leveling
- Four adjustable heavy-duty epoxy-coated shelves per door adjustable on 1/2" pilasters
- Merchandiser profile matches other KSGRP/KSGFP refrigerator and freezer models

DOORS

- Auto-close, triple pane, heated safety glass doors with heated frames
- Contemporary style black door frame and handles
- Heavy-duty universal workflow handles
- Easily replaceable snap-in magnetic vinyl door gaskets
- Standard door swing configuration:
 - 1-door hinged right
 - 2-door left door hinged left, right door hinged right
 - 3-door left door hinged left, middle door hinged right, right door hinged right
- Maximum visibility with these door sizes:
 - KSGFP23-HG 26" x 55¹/₂"
 - KSGFP27-HG 29" x 55¹/₂"
 - KSGFP48-HG & KSGFP74-HG 25" x 55¹/₂"

REFRIGERATION

- Self-contained bottom mount refrigeration system designed for optimum energy efficiency and low noise
- ENERGY STAR qualified, may be eligible for rebate programs

- Top mounted, low profile interior evaporator housing
- Energy-free condensate removal
- Refrigerant: R-404A
- Temperature range: 5° to -15°F (-18° to -26°C)

WARRANTY

- **Standard limited three year parts and labor**
- **Additional two year coverage on compressor part**

OPTIONS

- Casters
- Additional shelving



KSGFP-HG SERIES
BOTTOM MOUNTED SWINGING GLASS DOOR FREEZER
MERCHANDISERS WITH LIGHTED SIGN

TECHNICAL SPECIFICATIONS

MODEL	DIMENSIONS (in.)			DIMENSIONS (mm)			VOLTS	AMPS	UNIT H.P.	NO. OF DOORS	NO. OF SHELVES	SHELF SIZE (in.)	CAP. CU. FT.
	L	D*	H	L	D*	H							
KSGFP23-HG	27	30	79	686	762	2007	115	7.5	3/4	1	4	22 1/2 L x 21 1/2 D	22.1
KSGFP27-HG	30	30	79	762	762	2007	115	7.5	3/4	1	4	25 1/2 L x 21 1/2 D	25.0
KSGFP48-HG	52	30	79	1321	762	2007	115	12.3	1	2	8	23 1/2 L x 21 1/2 D	45.7
KSGFP74-HG	78	30	79	1981	762	2007	115/ 208-230**	12.8	1 1/4	3	12	23 1/2 L x 21 1/2 D (outer doors), 25 1/2 L x 21 1/2 D (middle door)	70.2

*Does not include door handle. **208-230/60/1 also requires neutral and safety ground wire.

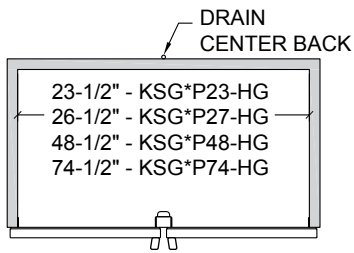

PLAN VIEW

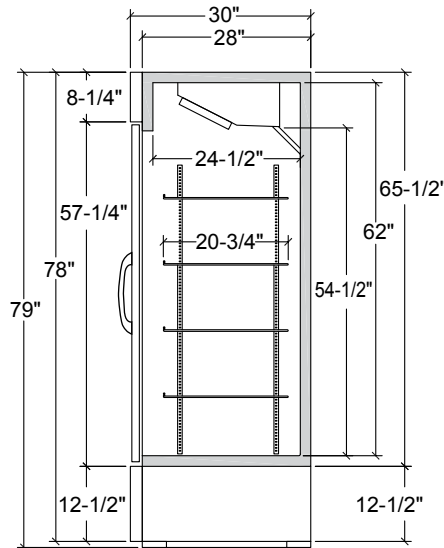

SIDE VIEW

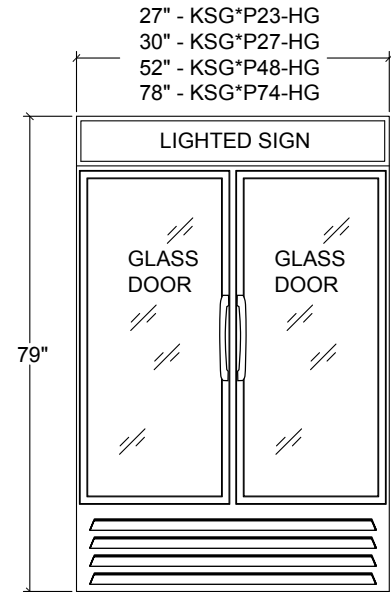

ELEVATION VIEW

LISTINGS



- Listed under NSF-7 for the storage and/or display of packaged food
- Meets 2012 Federal DOE Requirements
- Meets Canadian energy efficiency regulations

HOOKUP

All models except KSGFP74-HG via plug in, 10 foot long, flexible three wire 14/3 cord with molded plug.

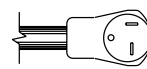

NEMA 5-20P (all models except KSGFP74-HG)

KSGFP74-HG via plug in, 10 foot long flexible four wire 208-230v 14/4 cord with neutral and ground wires and molded plug.

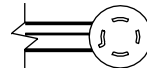

NEMA L14-20P (KSGFP74-HG)

BID SPECIFICATIONS

Item no. KSGFP_____-HG. Provide _____ Bottom Mounted Swinging Glass Door Freezer Merchandiser(s) With Lighted Sign, Kool Star model no. KSGFP_____-HG.

Merchandiser will be constructed of 24 gauge painted textured galvanized steel interior and exterior. Standard equipment will include interior LED lighting, programmable electronic controller system, top backlit

graphic panel and four epoxy-coated shelves per door adjustable on 1/2" pilasters.

Doors will be Auto-close, triple pane, heated safety glass doors with heated frames.

Refrigeration system will be self-contained and designed for optimum energy efficiency and low noise. Also standard will be an energy-free condensate removal system.

The refrigerant will be R-404A and the tem-

perature range will be 5° to -15°F (-18° to -26°C).

Merchandiser to have standard limited three year parts and labor warranty with additional two year coverage on compressor part. Merchandiser to be UL and C-UL listed, UL EPH classified, and ENERGY STAR qualified. Merchandiser will also meet Canadian energy efficiency regulations.

NOTE: Cabinet designed for optimum performance in air-conditioned area at 75°F ambient and 55% relative humidity. All specifications subject to change without notice.