

ITEM NO. _____
 PROJECT _____
 LOCATION _____
 DATE _____ QTY. _____



KSPT67



KSPT SERIES Pizza Prep Units

MODELS

- KSPT44 KSPT67 KSPT93



Drop-in section:

- Fans force cold air into this enclosed area keeping stored food items consistently cold
- A stainless steel divider prevents food spillage into the storage area beneath
- Accommodates 6" deep pans (4" standard)

FEATURES

CONSTRUCTION

- Stainless steel interior and exterior
- Foamed-in-place with low ODP polyurethane insulation
- Wall thickness: 1.75"
- Insulated top lids
- 1/2" thick, 19" deep reversible cutting board
- Standard 1/3 size pans
- Adjustable heavy-duty vinyl-coated shelves
- 6" diameter casters

DOORS

- Self-closing
- Heavy-duty ergonomic handle
- Standard door swing configuration:
 - KSPT44 hinged left
 - KSPT67 left hinged left, right hinged right
 - KSPT93 left hinged left, middle hinged left, right hinged right

Door width:

- KSPT44 29⁷/₈"
- KSPT67 and KSPT93 26"

REFRIGERATION

- Self-contained forced air refrigeration system
- Coated evaporator coil
- Refrigerant:
 - KSPT44 and KSPT67 R134a
 - KSPT93 R404A
- Temperature range: 32° to 40°F (0° to 4° C)

WARRANTY

- **Standard limited three year parts and labor**
- **Additional two year coverage on compressor part**

OPTIONS

- Single or double overshelf



- Refrigerated drawers



BID SPECIFICATIONS

Item no. KSPT____. Provide ____ Pizza Prep Unit(s), Kool Star model no. KSPT_____.

Prep unit will be constructed of stainless steel interior and exterior. Standard features will include a 1/2" thick, 19" deep reversible cutting board, 1/3 size pans, insulated lids,

adjustable heavy-duty vinyl-coated shelves and 6" diameter casters.

The refrigeration system will be self-contained. KSPT44 and KSPT67 will contain R-134a refrigerant while the KSPT93 will contain R404A. The temperature range will be 32°

to 40°F (0° to 4° C).

Prep unit to have standard limited three year parts and labor with additional two year coverage on compressor part.

Prep unit to be UL, C-UL and ETL Sanitation listed.

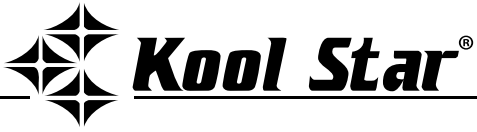

TECHNICAL SPECIFICATIONS

MODEL	DIMENSIONS (in.)			DIMENSIONS (mm)			VOLTS	AMPS	UNIT H.P.	NO. OF DOORS	NO. OF SHELVES	NO. OF PANS	CAP. CU. FT.	SHIP CU. FT.	SHIP WT. (LB/KG)
	L	D*	H**	L	D*	H**									
KSPT44	44 ³ / ₈	36 ¹ / ₂	42 ⁷ / ₈	1127	927	1089	115	6.5	3/8	1	2	(6) 1/3	9.7	43.2	309/140
KSPT67	67	36 ¹ / ₂	42 ⁷ / ₈	1702	927	1089	115	6.5	3/8	2	4	(9) 1/3	17.8	64.4	548/249
KSPT93	93 ¹ / ₄	36 ¹ / ₂	42 ⁷ / ₈	2369	927	1089	115	7.5	1/2	3	6	(12) 1/3	27.2	89.0	698/317

*Depth includes cutting board. **Height includes casters.

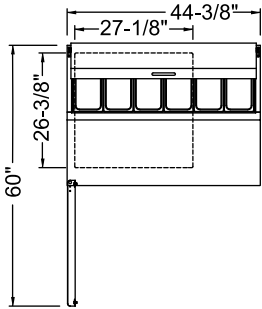

KSPT44 PLAN VIEW

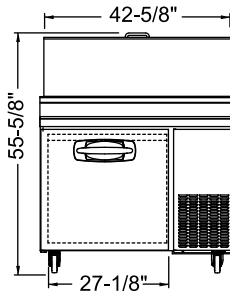

KSPT44 ELEVATION VIEW

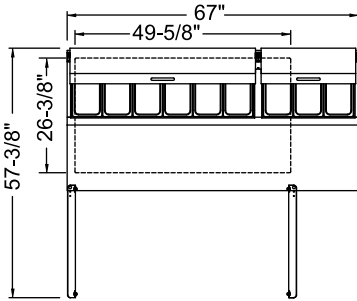

KSPT67 PLAN VIEW

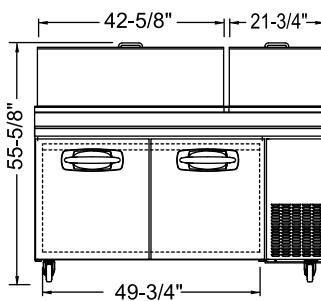

KSPT67 ELEVATION VIEW

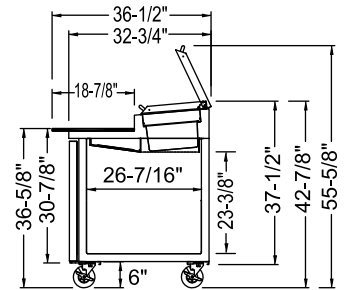

SIDE VIEW - ALL MODELS

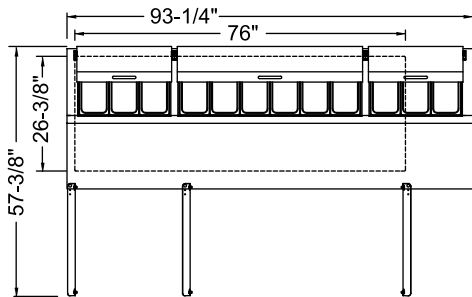

KSPT93 PLAN VIEW

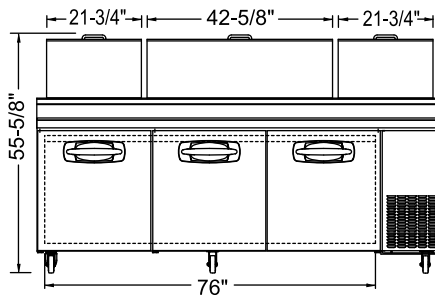

KSPT93 ELEVATION VIEW

HOOKUP

All models via plug in, 9 foot long flexible three wire 14/3 cord with molded plug.

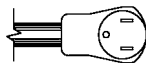

NEMA 5-15P

OPTIONAL REFRIGERATED DRAWER CONFIGURATIONS

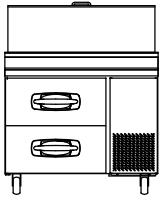

KSPT44-001

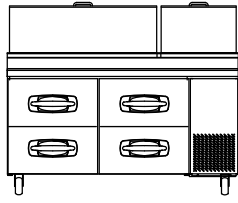

KSPT67-001

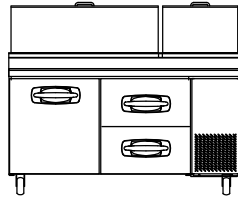

KSPT67-002

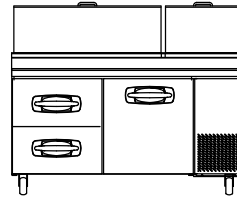

KSPT67-003

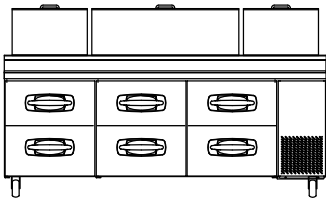

KSPT93-001

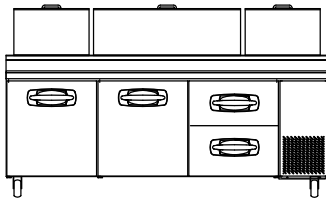

KSPT93-002

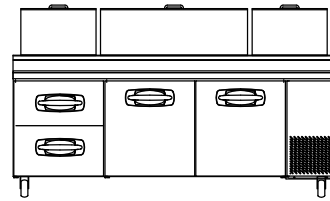

KSPT93-003

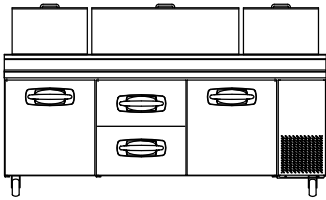

KSPT93-004

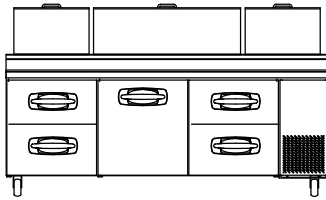

KSPT93-005

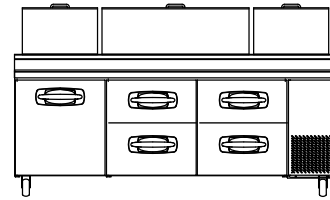

KSPT93-006

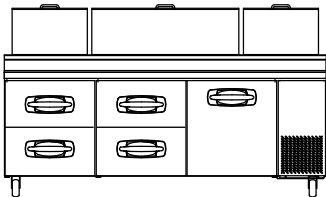

KSPT93-007

PAN CONFIGURATIONS FOR REFRIGERATED DRAWERS

KSPT44

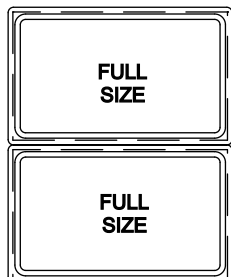

TOP & BOTTOM DRAWERS

DRAWER FRONT



KSPT67 & KSPT93

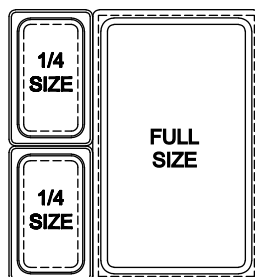

TOP & BOTTOM DRAWERS

DRAWER FRONT



*U.S. size pans, pans provided by others

Drawers accept up to 6-inch deep pans.

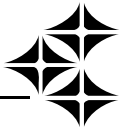

OPTIONAL OVERSHELF SPECIFICATIONS

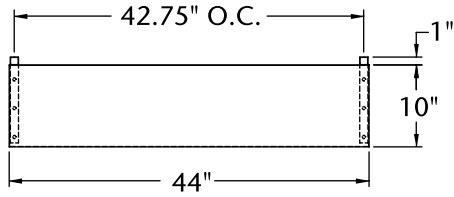

PLAN VIEW KSPT44

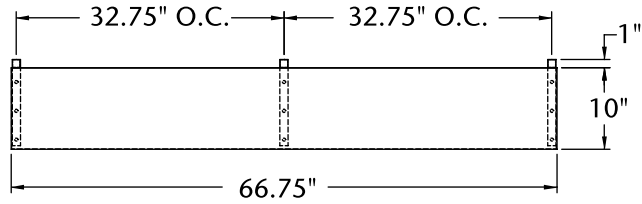

PLAN VIEW KSPT67

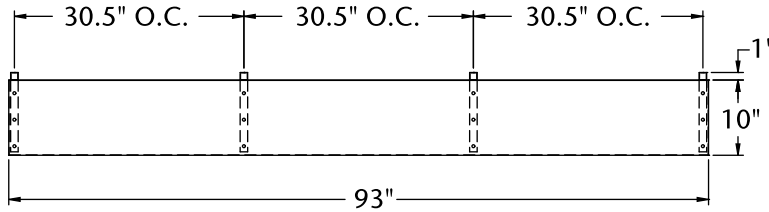

PLAN VIEW KSPT93

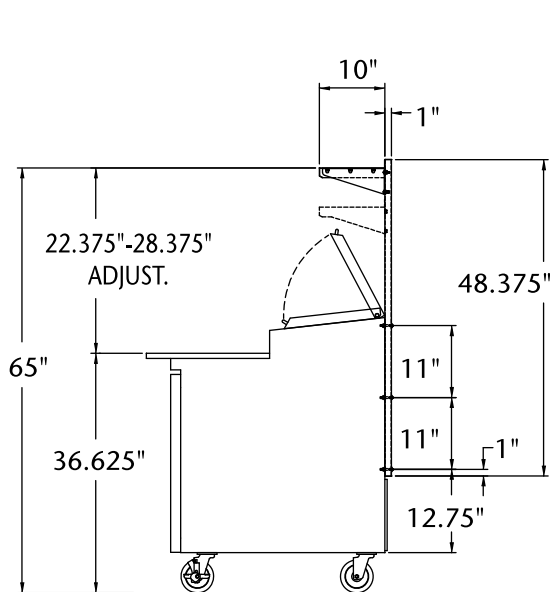

SINGLE SHELF SIDE VIEW

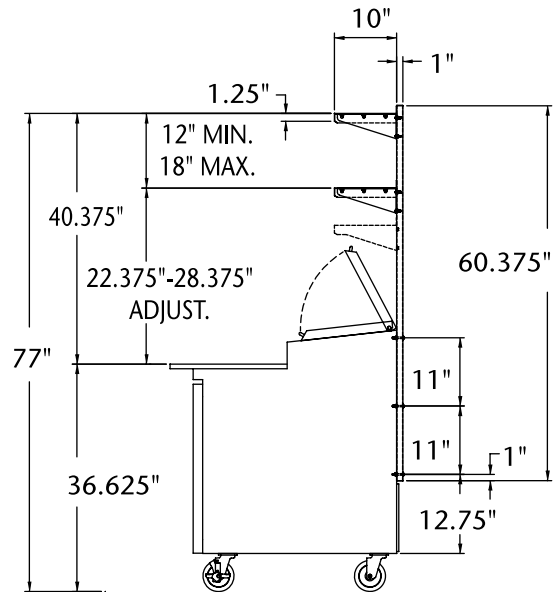

DOUBLE SHELF SIDE VIEW

NOTE: Cabinet designed for optimum performance in air-conditioned area at 75°F ambient and 55% relative humidity.
All specifications subject to change without notice.