

# Breakfast / Snack Carts

## Stainless Steel



Model 768  
Shown with optional  
hot and cold wells,  
and menu sign.



Model 764  
Shown with optional drop leaf.



Optional warming/  
chilled/utility drawers



Optional height-adjustable  
wicker baskets mount to  
support posts.

### Add Mobility And Flexibility To Condiment Serving

#### Benefits

- Provide nutritious breakfast and snacks in various locations
- Rolls easily to serving location
- Colorful graphics attract students

#### Features

- Stainless steel welded cabinet with laminate top
- Variable-height overhead graphic banner with LED lighting (120V, 15A)
- Choice of standard or custom laminate finishes and graphics
- 33" high cash register shelf (Model 768)
- Ergonomic vertical push handles
- 18" drop leaf with swing-out support (optional on Model 764)
- Spacious interior storage compartment

#### Casters

- All-swivel 5" cushion tread, 2 with brakes

#### Standard Front And Top Panel Graphics Choices



#### Specifications:

Shall be Lakeside model \_\_\_\_\_ (764, 768) and shall have a 20-gauge stainless steel base cabinet with laminate exterior and top and stainless steel interior compartment with 18-gauge floor for ease of cleaning and sanitation. Unit shall feature variable-height overhead panel mounted on 1½" diameter stainless steel support posts to accept merchandising graphics. Panel shall be 12" H x 65" W (39" W on #768) and feature attached LED light strip (120V, 15A) to illuminate counter top. Cart shall have 4 ea. 5" cushion tread casters, all-swivel, 2 ea. with brake. Casters shall be mounted to a 18-gauge stainless steel dolly for extra strength.

**Model 768:** Shall have dual-height top to accommodate cash register and 18" rounded dropleaf (33" height) with swing-out support.

Spec. # \_\_\_\_\_

AIA # \_\_\_\_\_

# Breakfast / Snack Cart

Stainless Steel

Spec. #

AIA #

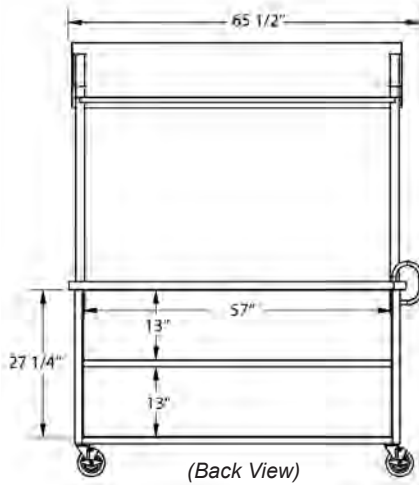
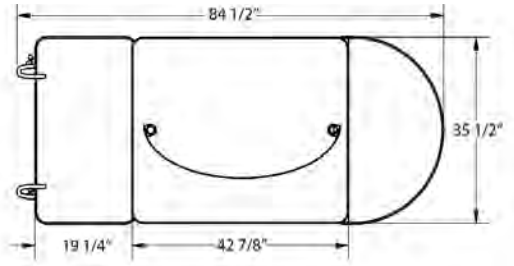
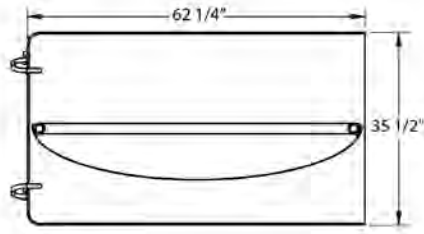

Model 764

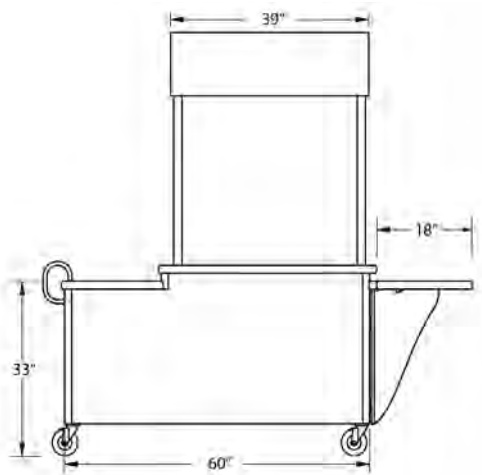
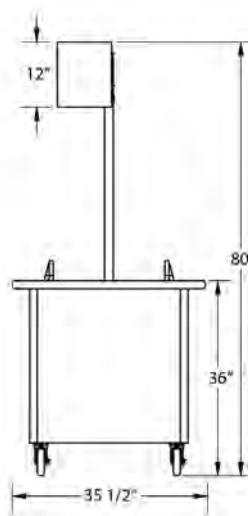

Model 768

## Model Information:

Model	Description	Counter Height	Top Size		Overall Size			Case Wt. Lbs. (Kg)
			W	L <sup>1</sup>	W	L <sup>2</sup>	H <sup>3</sup>	
764	Flat Top	36" (927)	35 1/2" (902)	62 1/4" (1581)	35 1/2" (902)	65 1/2" (2159)	80" (2032)	239 (108.4)
768	2-Level Top w/Drop Leaf	Top 36" (927) Cashier Shf. 33" (832)	35 1/2" (902)	62 1/4" (1581)	35 1/2" (902)	84 1/2" (2146)	80" (2032)	260 (117.9)

Dimensions in ( ) denote metric millimeters, unless otherwise noted. Please specify laminate choice.  
<sup>1</sup>With leaf down. <sup>2</sup>With leaf up (#768). <sup>3</sup>With support posts fully extended.

## Available Laminate Finishes



Walnut     Gray Sand     Light Maple     Victorian Cherry



Beige Suede     Hard Rock Maple     Red Maple     Red     Green     Black     Royal Blue     Purple

## Options:

- Battery pack for LED lights
- Custom graphics
- 18" drop leaf (Model 764)
- Warming drawer(s) \_\_\_
- Eutectic chilled drawer(s) \_\_\_
- Heated well(s) \_\_\_
- Eutectic chilled well(s) \_\_\_
- Custom laminate
- Utility drawer(s) \_\_\_
- Menu sign



Lakeside Manufacturing, Inc.  
 4900 West Electric Avenue • West Milwaukee, WI 53219 U.S.A.  
 800-558-8565 • 414-902-6400 • Fax 414-902-6446 • www.eLakeside.com