



Item No. _____
 Project _____
 Quantity _____

**Gas, Half Size Combi Oven
 Manual or Programmable Controls**

Visual Cooking
Models: C1.06 Gas & CPE1.06 Gas



*Model CPE1.06 Gas shown
 (counter model)*

SHORT FORM SPECIFICATIONS

Shall be Lang model C1.06 Gas or CPE1.06 Gas. Compartment spacing will accommodate six 12" x 20" x 2.5" deep North American hotel pans. Unit is a boilerless model which is pressureless steam, combination steam and air or hot air. Unit comes with manual control with 10 programs (C), each with three steps or programmable controller featuring 200 recipe programs (CPE) with 10 cooking stages for each program. "CPE" Unit features HAACP quality control, Delta T cooking and USB connectivity.

LANG COMBI FEATURES

- Steam injection based system
- Reversible fan ensures perfect roasting and baking
- Adjustable fan speed with 9 steps
- Optional door hinging, left (standard) or right
- Two stage door safety latch
- Door mounted drip tray
- Holds six 12" x 20" x 2.5" pans
- Cabinet and oven chamber in 304 stainless steel
- Rounded corners in oven chamber
- Easily detachable door seal
- Halogen light in oven chamber
- Counter model prepared for stand integration
- Timer function with current time, date and timer
- Manual humidity pulsing
- Preheating up to 575°F (300°C)
- Factory start up inspection performed by Lang authorized service agent

SAFETY FEATURES

- Oven door with ventilated heat-reflecting glass
- CTD Cool Touch Door
- 2-step door handle in stainless steel for optimum safety
- Integrated drip tray in stainless steel, self-emptying
- Automatic door stop at 110° and 180°
- Runners with stop

C1.06 GAS OVEN STANDARD FEATURES

- CombiWash® fully automatic cleaning system
- Panel with turn switch and digital display
- Memory of 10 programs - each with up to 3 steps
- Combi 1 and Combi 2: 86-482°F (30° to 250° C) temp range
- Automatic cooling
- Error registration system
- Integrated hand shower
- Multi-point probe, external location



CPE1.06 GAS OVEN STANDARD FEATURES

- CombiWash® fully automatic cleaning system
- Panel with soft keys and TFT display
- Memory of 200 programs - each with up to 10 steps
- ClimaOptima® automatic humidity control: 158-482°F (70°C to 250°C)
- Proving: 86-104°F (30°C to 40°C)
- Integrated hand shower
- Manual or automatic cooling
- Automatic service diagnosis system
- Multi-point probe, external location
- Automatic service diagnosis
- Delta-T and Cook & Hold
- HACCP quality control record keeping with documentation
- USB connection for transfer of menu items and data



OPTIONS

- Extra multi-point probe, external location (C,CPE)
- Removable cassette rack or rack for plates
- Trolley for rack
- Insulating thermal blanket
- Stacking kit for CombiPlus (1.06 & 1.10)
- Marine version
- Stands e.g. with runners or shelf
- Various voltages – contact factory first
- CombiNet for remote control and monitoring oven through the internet or computer
- Right Hinge Combi Door – Must be placed at time of order. **No charge accessory. Contact factory for lead times.**

STANDARD PRODUCT WARRANTY

- Two year parts and labor



Sheet No. LSP-C09 (rev. 11/12)

**Gas, Half Size Combi Oven
Manual or Programmable Controls**

Visual Cooking
Models: C1.06 Gas & CPE1.06 Gas

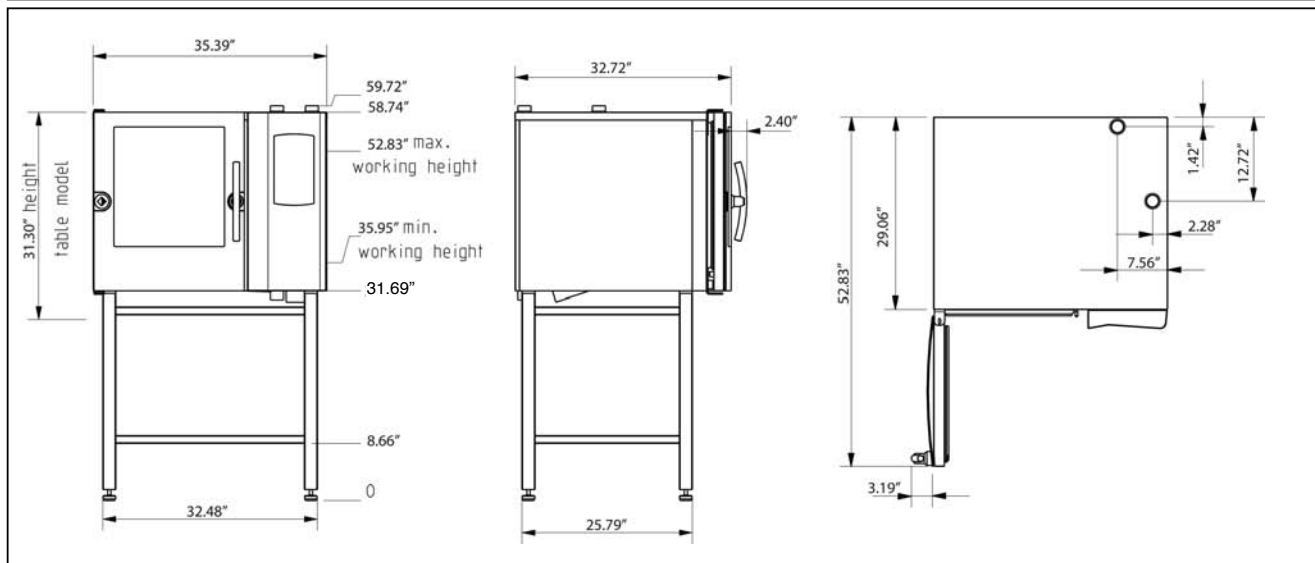

[Front View/Elevation]

[Left Side View]

[Top View/Plan]

DIMENSIONS	OVEN
Width	35.4"
Height - Counter Model	31.3"
Height With Stand	58.7"
Depth (excl. handle)	32.7"
Weight	298 lbs.

CAPACITY	OVEN
Number of runners, 2.56 in.	(6) 12" x 20" x 2.5" Pans
SPECIFICATIONS	OVEN
Voltage	120V/1
kW	1.2
Amperage	10
Water Connection	3/4"
Drain	2
Gas Supply	3/4" NPT
BTUs	41,000

MINIMUM WATER QUALITY

• Cold water, 30 to 80 PSI	- Chlorides less than 30 PPM
• pH between 6.8 and 7.6	- Sulfates less than 40 PPM
• Conductivity less than 1/500,000W per inch	- Iron less than 0.1 PPM
• Total dissolved solids less than 100 PPM	- Copper less than 0.05 PPM
• Hardness from 5.3 to 7.3 grains per gallon	- Manganese less than 0.05 PPM
• Maximum Salinity Ion Content:	- Chloramines less than 0.5 PPM
- Chlorine less than 0.5 PPM	

CAD SYMBOLS & PRICING



Due to continuous improvements, specifications subject to change without notice.

LANG MANUFACTURING • 10 SUNNEN DR. ST. LOUIS, MO 63143
PHONE: 314-678-6315 • FAX: 314-781-3636 • www.langworld.com

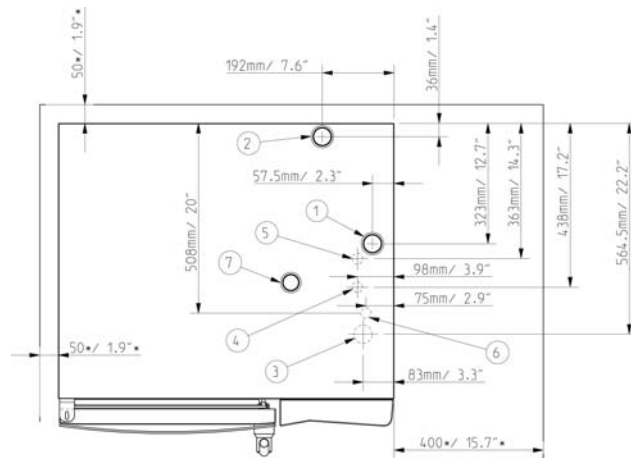

*= Recommended minimum distance

- ① 50 mm/2" exhaust tube (airgab must be provided)
- ② 50 mm/2" tube for drain connection
- ③ Lead-in for supply line
- ④ 3/4" water connection for soft water (max.3"dh) standard
- ⑤ Option together with ④ 3/4" water connection for raw water
- ⑥ 3/4" Gas connection
- ⑦ 45 mm/1.8" exhaust tube for heat exchanger

Do not connect the oven to a closed drain and a closed exhaust system, without fitting the special adapter from Lang

For further information, consult your service and installations manual.

IMPORTANT: It is the responsibility of the purchaser to install and maintain the water supply to Lang equipment. Failure to provide satisfactory water quality to operate the oven properly can cause damage to integral components and void your warranty. This oven must be installed to comply with the applicable federal, state or local plumbing codes.

Lang offers water treatment products and recommends using Everpure products to properly filter your water. Using these products will protect your investment and helps to maintain the warranty of the combi.