



**Electric, Slim Size Combi Oven
Manual or Programmable Controls**

Item No. _____
Project _____
Quantity _____

Micro Combi Series
Models: CSC1.10 & CSCPE1.10



*Model CSCPE1.10 shown
(counter model)*

SHORT FORM SPECIFICATIONS

Shall be Lang model CSC1.10 or CSCPE1.10. Compartment spacing will accommodate ten 12" x 20" x 2.5" deep North American hotel pans. Unit is a boilerless model which is pressureless steam, combination steam and air or hot air. Unit comes with manual control with 10 programs (C), each with three steps or programmable controller featuring 200 recipe programs (CPE) with 10 cooking stages for each program. "CPE" Unit features HACCP quality control, Delta T cooking and USB connectivity.

LANG COMBI FEATURES

- Steam injection based system
- Reversible fan ensures perfect roasting and baking
- Adjustable fan speed with 9 steps
- Two stage door safety latch
- Door mounted drip tray
- Holds ten 12" x 20" x 2.5" pans
- Cabinet and oven chamber in 304 stainless steel
- Easily detachable door seal
- Halogen light in oven chamber
- Counter model prepared for stand integration
- Timer function with current time, date and timer
- Manual humidity pulsing
- Preheating up to 575°F (300°C)
- Factory start up inspection performed by Lang authorized service agent

SAFETY FEATURES

- Oven door with ventilated heat-reflecting glass
- CTD Cool Touch Door
- Integrated drip tray in stainless steel, self-emptying

CSC1.10 OVEN STANDARD FEATURES

- Semi-automatic cleaning system
- Panel with turn switch and digital display
- Memory of 10 programs - each with up to 3 steps
- Combi 1 and Combi 2: 86-482°F (30° to 250° C) temp range
- Automatic cooling
- Error registration system
- Integrated hand shower
- Multi-point probe



CSCPE1.10 OVEN STANDARD FEATURES

- CombiWash® fully automatic cleaning system
- Panel with soft keys and TFT display
- Memory of 200 programs - each with up to 10 steps
- ClimaOptima® automatic humidity control: 158-482°F (70°C to 250°C)
- Proving: 86-104°F (30°C to 40°C)
- Integrated hand shower
- Manual or automatic cooling
- Automatic service diagnosis system
- Multi-point probe
- Automatic service diagnosis
- HACCP quality control record keeping with documentation
- USB connection for transfer of menu items and data

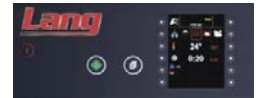

OPTIONS

- Stacking kit for 1.06 to 1.06 or 1.06 to 1.10
- Various voltages – contact factory first

STANDARD PRODUCT WARRANTY

- Two year parts and labor



Sheet No. LSP-C08 (rev. 11/12)

**Electric, Slim Size Combi Oven
Manual or Programmable Controls**

Micro Combi Series
Models: CSC1.10 & CSCPE1.10

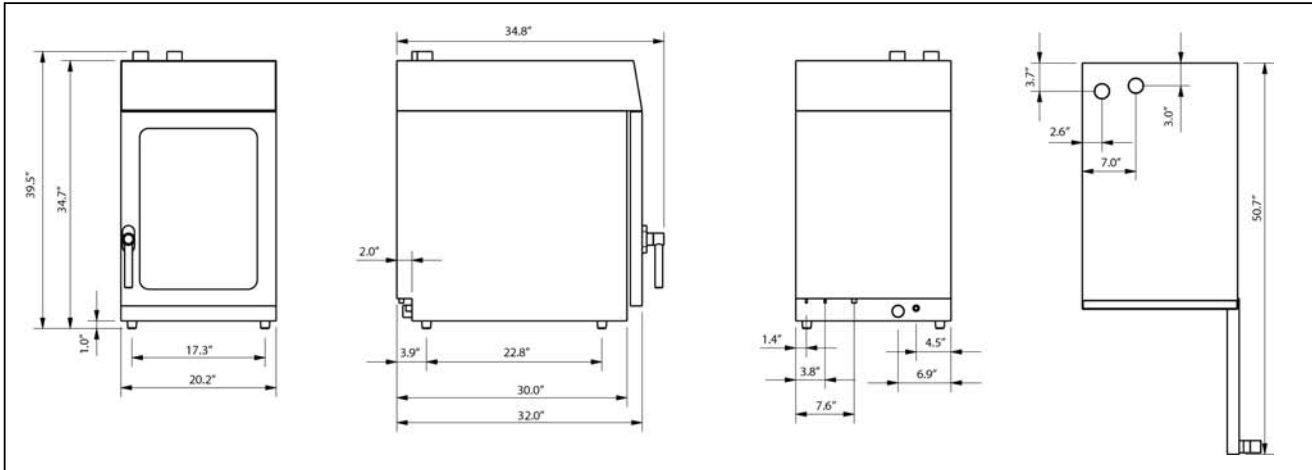

[Front View]

[Left Side View]

[Rear Plan]

[Top View]

DIMENSIONS	OVEN
Width	20.20"
Height - Counter Model	34.96"
Depth (including handle)	33.85"
Weight	180 lbs.

CAPACITY	
Number of runners, 2.56"	(10) 12 x 20 x 2.5 Pans

SPECIFICATIONS	
Voltage	208/3
kW	10.5
Amperage	29
Water Connection	3/4"
Drain	1.5"

MINIMUM WATER QUALITY

• Cold water, 30 to 80 PSI	- Chlorides less than 30 PPM
• pH between 6.8 and 7.6	- Sulfates less than 40 PPM
• Conductivity less than 1/500,000W per inch	- Iron less than 0.1 PPM
• Total dissolved solids less than 100 PPM	- Copper less than 0.05 PPM
• Hardness from 5.3 to 7.3 grains per gallon	- Manganese less than 0.05 PPM
• Maximum Salinity Ion Content:	- Chloramines less than 0.5 PPM
- Chlorine less than 0.5 PPM	

IMPORTANT: It is the responsibility of the purchaser to install and maintain the water supply to Lang equipment. Failure to provide satisfactory water quality to operate the oven properly can cause damage to integral components and void your warranty. This oven must be installed to comply with the applicable federal, state or local plumbing codes.

Lang offers water treatment products and recommends using Everpure products to properly filter your water. Using these products will protect your investment and helps to maintain the warranty of the combi.

CAD SYMBOLS & PRICING



Due to continuous improvements, specifications subject to change without notice.

LANG MANUFACTURING • 10 SUNNEN DR. ST. LOUIS, MO 63143
PHONE: 314-678-6315 • FAX: 314-781-3636 • www.langworld.com