



Item No. \_\_\_\_\_

Project \_\_\_\_\_

Quantity \_\_\_\_\_

## Electric, 24" Clamshell® Hood With Griddle Model: [124,136,148]TH, 148THS or CSE24



Model 136TH with optional grooving and optional ES-G36C stand

### SIZING AND PERFORMANCE GUIDE:

Model	Lower Griddle			
	Width	Surface Area	Controls	Power
<input type="checkbox"/> 124TH	24"	552 sq. in.	2	12-kW
<input type="checkbox"/> 136TH	36"	828 sq. in.	3	18-kW
<input type="checkbox"/> 148TH	48"	1104 sq. in.	4	24-kW
<input type="checkbox"/> 148THS	48"	1104 sq. in.	4	24-kW

Model	Clamshell®		
	Width	Location	Power
<input type="checkbox"/> [124,136,148]TH	24"	Left	6-kW
<input type="checkbox"/> CSE-24-0	24"	Slides	6-kW

### SHORT/BID SPECIFICATION

Two sided cooker shall be a **LANG Manufacturing** Model:  124TH  136TH  148TH  148THS [Specify One] Clamshell® & Griddle combination featuring a 24, 36 or 48" wide electric heated smooth griddle; with 1" thick polished cooking surface; ACCU-TEMP Snap-action controls for each 12" of griddle surface; plus an electric heated Clamshell® Hood, factory mounted on left side; with six sheathed infrared heating elements, enclosed in a stainless steel hood, hinged to a mounting bracket with spring assisted lift; auto-ON when unit is lowered; a 3" gap from the griddle surface; and all the features listed.

### STANDARD PRODUCT WARRANTY

One year, parts & labor

### CONSTRUCTION FEATURES

- 1" thick precision machined, polished steel cooking surface
- Continuously bottom welded 5-1/2" high rear & side splash shields
- Full front 3-1/2" wide X 1" deep stainless steel grease trough
- 8 quart capacity grease drawer, with removable fully enclosed sleeve
- All stainless steel base cabinet construction
- 4" adjustable legs provided [Stand option available]
- Stainless steel, hinged, spring assisted upper platen/hood
- Infrared heating elements protected by stainless sheathing
- Enclosed, air cooled control compartment

### PERFORMANCE FEATURES

- Two-sided cooking reduces cook times and increases production
- 1400°F infrared heating rapidly browns, seals in juices and speeds cooking
- Preset 3" clearance from griddle handles variations in product thickness
- 148THS Sliding Model provides more production flexibility or multi-product use
- Thick griddle plate reduces hot & cold spots and retains heat
- Highly polished surface and continuously welded splash and grease trough speed cleanup
- Heating elements Incoloy sheathed for long life
- Elements are pressure clamped to bottom of griddle plate for more even heating
- Air cooled control panel protects controls for heat damage
- Accurate griddle surface temperature control between 175° and 450°F

### CONTROL PACKAGE

#### ACCU-TEMP™ Thermostat Controls [Standard]

- Snap-action thermostats every 12"
- Power-to-element pilot lights for each control
- Instant-ON when Clamshell is lowered
- Automatically turns OFF when hood is lifted



Sheet No. LSP-CS3 (rev. 06/07)

# Electric, 24" Clamshell® Hood With Griddle Model: [124,136,148]TH, 148THS or CSE24

## INSTALLATION REQUIREMENTS

- Two electric connections required. ⓔ1 for griddle base unit: 208 or 240V, 1-phase or 3-phase. ⓔ2 for Clamshell unit: 208V or 240V, 1-phase only
- Installation under approved vent hood required. [Connections from rear. See other below for location and power requirements]

## OPTIONS & ACCESSORIES

- Grooved griddle surface, in 12" increments [Add G suffix to Model No.]
- Split voltage 208V Clamshell on 480V equipment
- Clamshell location change to center or right [from standard left-side]
- Stainless steel tubular-leg stand with undershelf & adjustable feet
- Stainless steel tubular-leg stand with undershelf & casters

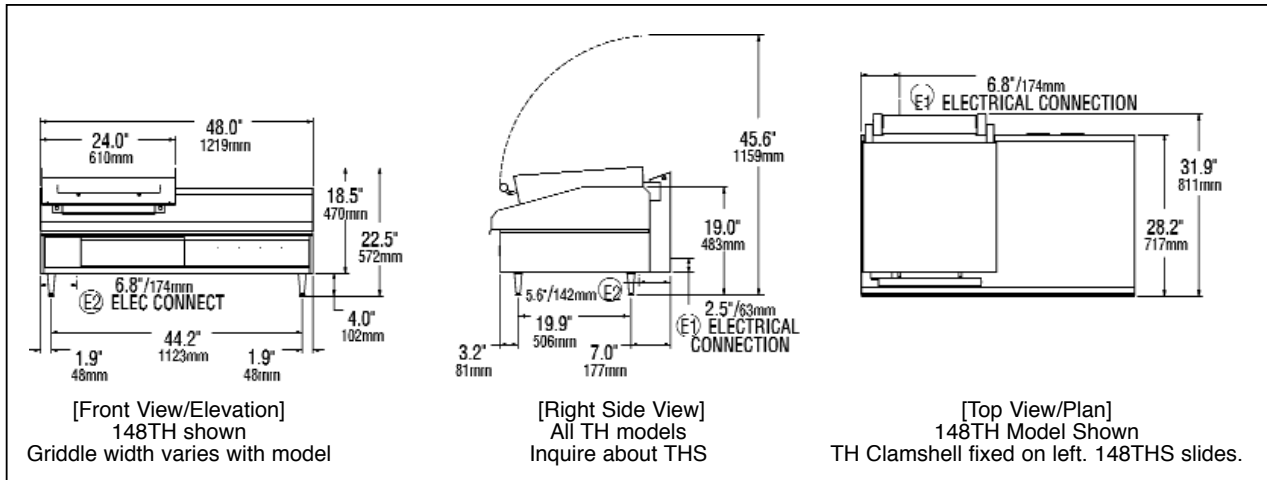

Model	Height x Width x Depth (Not including legs, Clamshell® open)	Clearance from combustible surface	Weight		Freight Class
			Actual	Shipping	
124TH	45.6" x 24.0" x 31.9" 1158mm x 610mm x 811mm	Sides: 2" Back: 2"	298 lbs. 135 kg	335 lbs. 152 kg	85
136TH	45.6" x 36.0" x 31.9" 1158mm x 914mm x 811mm		428 lbs. 195 kg	470 lbs. 214 kg	85
148TH	45.6" x 48.0" x 31.9" 1158mm x 1219mm x 811mm		568 lbs. 258 kg	590 lbs. 268 kg	85
148THS	46.2" x 48" x 34.7" 1173mm x 1219mm x 881mm		643 lbs. 292 kg	690 lbs. 314 kg	85

Model	ⓔ1 KW Lower Griddle	Maximum AMP Per Line				ⓔ2 KW Clamshell	Maximum AMP Per Line	
		208V 3 Phase	240V 3 Phase	208V 1 Phase	240V 1 Phase		208V 1 Phase	240V 1 Phase
124TH	12	50.0	43.3	57.7	50.0	6	28.9	25.0
136TH	18	50.0	43.3	86.5	75.0	6	28.9	25.0
148TH	24	75.0	65.0	115.2	100.0	6	28.9	25.0
148THS	24	75.0	65.0	115.2	100.0	6	28.9	25.0

\* Load split for the two power connections required.

## CAD SYMBOLS & PRICING



Due to continuous improvements, specifications subject to change without notice.



Sheet No. LSP-CS3 (rev. 06/07)

LANG MANUFACTURING - A DIVISION OF STAR MANUFACTURING INT'L, INC. • 10 SUNNEN DR. ST. LOUIS, MO 63143  
TOLL FREE: 800.264-7827 • FAX: 314-781-3636 • www.langworld.com