



Item No. _____

Project _____

Quantity _____

Electric, One-Pan Deck Ovens

Model: D036[1,2,3]



Model D0362 shown

PAN & PRODUCTION CAPACITY GUIDE

Capacity/Model:	D0361*	D0362	D0363
18" x 26" Full Sheet	1	2	3
Pies - 9"	6	12	18
Bread - 1 lb. loaves	10	20	30

* Or the D036 Model

SHORT/BID SPECIFICATION

Deck Oven[s] shall be **LANG Manufacturing Model D036__** [Insert 1, 2 or 3], a 6-kW [each] electric heated single-pan deck oven, with: space saving 36" overall width; solid, spring loaded pull-down door; all stainless steel exterior; insulated, aluminized steel cooking compartment; one heavy duty pan rack standard; plus all the features listed and options/accessories checked:

STANDARD PRODUCT WARRANTY

One year, parts & labor

CONSTRUCTION FEATURES

- Heavy duty 430 Series stainless steel exterior, with attractive No. 4 finish
- Cooking compartment is aluminized steel and fully insulated on six sides
- Heavy duty solid, insulated, pull-down door with handle
- Recessed, right side mounted control panel
- 27" [D0361], 16" [D0362] or 6" high [D0363] legs standard
- One heavy duty chrome plated wire rack provided

PERFORMANCE FEATURES

- Top & bottom mounted heating elements enclosed in Incoloy sheathing
- Narrow 36" width reduces hood space requirements
- Stackable up to three high, for more capacity in same footprint
- Solid, insulated door saves energy, keeps kitchen cooler
- Sturdy pull-down door serves as loading platform
- 100-450°F operating temperature range

CONTROL PACKAGE [Per Deck]

- Simple knob-set time and temperature controls
- 3-heat switch for: top only, bottom only or heat from both
- 60 minute timer
- Manual vent rod



Sheet No. LSP-D1 (rev. 06/07)

Electric, One Pan Deck Ovens

Model: D036[1,2,3]

INSTALLATION REQUIREMENTS

- ⓔ 208V or 240V, 1-Phase or 3-Phase power required; or 480V, 3-Phase as option
- Installation under approved vent hood may be required. Consult local codes. [Power connection[s] from bottom. See below]

OPTIONS & ACCESSORIES

- 480 Volt, 3-phase model, per oven deck
- 27" stainless steel angular legs for D0361 Model
- 16" stainless steel angular legs for D0362 Model
- 6" stainless steel tubular legs for D0363 Model
- Stainless steel oven liner & inner door, per oven deck
- Extra wire pan racks [one provided as std., per oven deck]

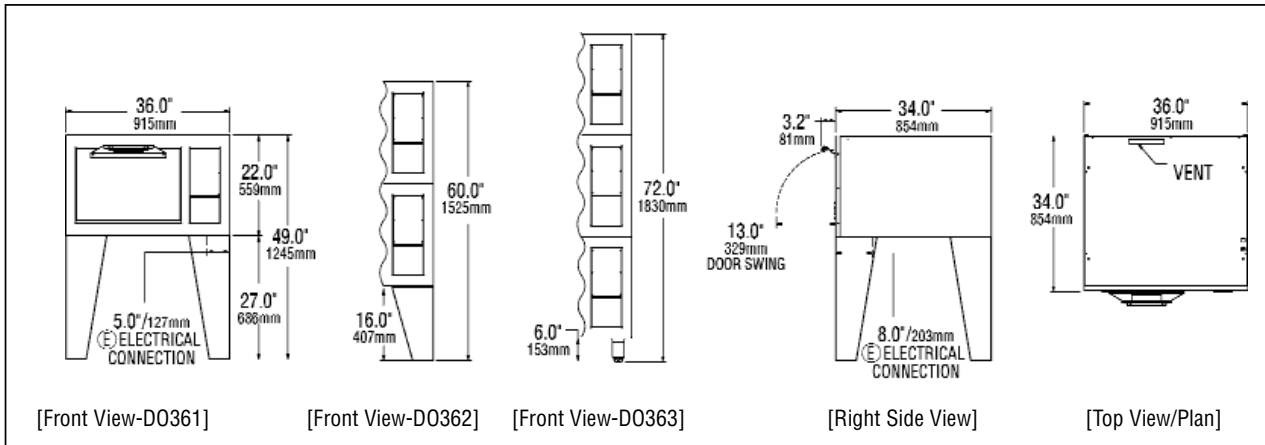

Model	Height x Width x Depth (without legs)		Clearance from combustible surface*	Weight		Freight Class
	External	Inside Oven Dimension		Actual	Shipping	
D0361	22.0" x 36.0" x 34.0" 559mm x 915mm x 854mm	12.0" x 22.0" x 27.8" 305mm x 559mm x 705mm	Sides: 2.0" (51mm) Back: 2.0" (51mm)	245 lbs. 111 kg	285 lbs. 130 kg	85
D0362	44.0" x 36.0" x 34.0" 1118mm x 915mm x 854mm	12.0" x 22.0" x 27.8" 305mm x 559mm x 705mm	Sides: 2.0" (51mm) Back: 2.0" (51mm)	415 lbs. 189 kg	495 lbs. 225 kg	85
D0363	66.0" x 36.0" x 34.0" 1676mm x 915mm x 854mm	12.0" x 22.0" x 27.8" 305mm x 559mm x 705mm	Sides: 2.0" (51mm) Back: 2.0" (51mm)	600 lbs. 273 kg	720 lbs. 327 kg	85

* Noncombustible floor only.

Voltage	ⓔ Electrical Requirements By Model						
	Phase	Model D0361		Model D0362		Model D0363	
		Total kW	Amps/Line	Total kW	Amps/Line	Total kW	Amps/Line
208V/60Hz	1	6.0	28.8	12.0	57.7	18.0	86.5
240V/60Hz	1	6.0	25.0	12.0	50.0	18.0	75.0
208V/60Hz	3	6.0	28.8	12.0	50.0	18.0	57.7
240V/60Hz	3	6.0	25.0	12.0	43.3	18.0	43.3
480V/60Hz	3	6.0	12.5	12.0	21.7	18.0	21.7

CAD SYMBOLS & PRICING



Due to continuous improvements, specifications subject to change without notice.



Sheet No. LSP-D1 (rev. 06/07)

LANG MANUFACTURING - A DIVISION OF STAR MANUFACTURING INT'L, INC. • 10 SUNNEN DR. ST. LOUIS, MO 63143
TOLL FREE: 800.264-7827 • FAX: 314-781-3636 • www.langworld.com