



Item No. \_\_\_\_\_

Project \_\_\_\_\_

Quantity \_\_\_\_\_

## 12" Adder Section for 36" Ranges

## Model: R12-[ATG,ATH, ATI]



Model R12-ATG shown

### CONFIGURATION GUIDE\*

<b>Model Has:</b>	<input type="checkbox"/> R12-ATG	<input type="checkbox"/> R12-ATH
<b>French Plates:</b>	-	2 each
<b>Hot Plates:</b>	1 each	-
<b>Pictogram:</b> [Unit Top View]		

\* See other side for additional spreader options.

### SHORT/BID SPECIFICATION

Adder Range Section shall be a LANG Manufacturing Model

R12-\_\_\_ [Specify one]:

- ATG, with 1 ea. 12" X 24" X 3/4" thick Hot Plate; or
- ATH, with 2 ea. 8" diameter French Plates
- ATI, with 12" unheated top

...a 12" wide heavy-duty electric heated unit designed to match 36" wide gas or electric Lang Range models; with all stainless steel exterior; individual cook-top component controls; plus the features listed and options/accessories checked:

### STANDARD PRODUCT WARRANTY

Two year, parts & labor

### CONSTRUCTION FEATURES

- One piece heavy duty 430 Series stainless steel exterior, with attractive No. 4 finish
- 6" adjustable legs standard
- 2" high range-top back riser
- 3" wide full width front grease trough
- 6" wide full width plate landing
- Grease drain in trough with full width & depth spillage drawers

### PERFORMANCE FEATURES

- Unit expands productivity of 36" Range, when space is available
- Choice of cook top configurations, to include:
  - 1 ea. 12" wide Hot Tops
  - 2 ea. 8" diameter French Plates
  - 12" unheated top
- Full front grease trough, grease drain & spillage drawers speed cleanup
- Full front landing simplifies and speeds plating
- Separate, independent controls allows simultaneous multi-function cooking

### CONTROLS [Varies By Top Configuration]

- [-ATG] One 450°F thermostat for Hot Top
- [-ATH] Two 6-heat level switches [ea. French Plate]



Sheet No. LSP-R6 (rev. 02/12)

# 12" Adder Section for 36" Ranges

# Model: R12-[ATG,ATH, ATI]

## INSTALLATION REQUIREMENTS

- (E) Single 208/240V, 1-phase; or 480V, 1-phase electrical connection
- Installation under approved vent hood required. Consult local codes.

[Power connection from bottom. See below]

## OPTIONS & ACCESSORIES

- ❑ Substitute a Griddle with 12 X 24 X 3/4" thick plate, w/splash guard
- ❑ Substitute 1" thick griddle plate for grooving [12" wide]
- ❑ Grooving on [1" thick ONLY] that Griddle Plate
- ❑ 480 Volt, 1-phase model
- ❑ 6" wide Top Spreader to bank with 36" Ranges
- ❑ 12" wide Top Spreader to bank with 36" Ranges
- ❑ 6" wide Front Enclosure, for use with 6" Top Spreader
- ❑ 12" wide Front Enclosure, for use with 12" Top Spreader

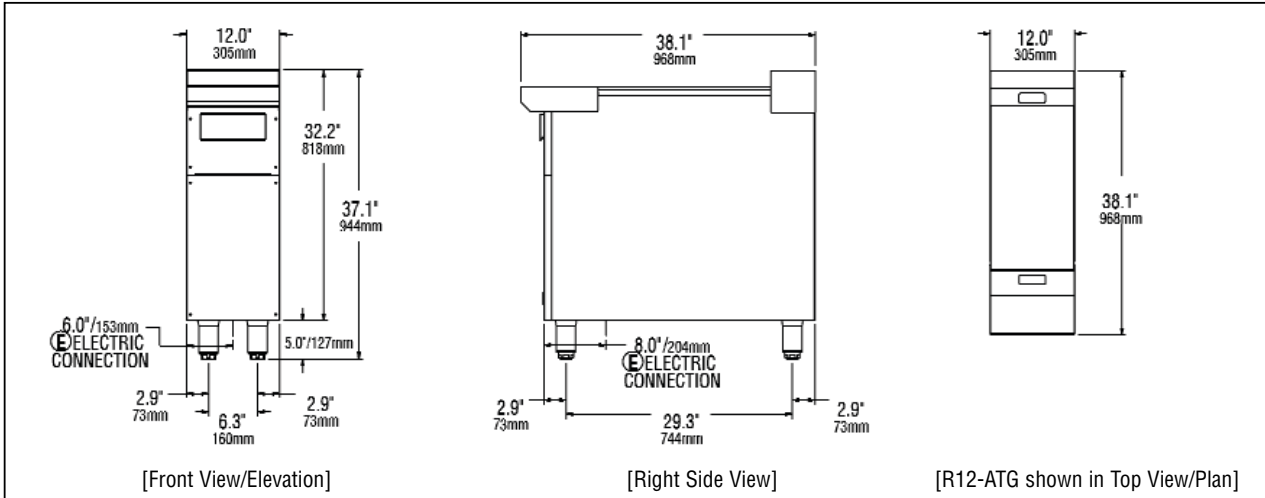

Model	Height x Width x Depth (With standard legs)	Clearance from combustible surface	Weight		Freight Class
			Actual	Shipping	
R12-ATG	37.1" x 12.0" x 38.1" 944mm x 305mm x 968mm	Sides: 4" (100mm) Back: 4" (100mm)	130 lbs.	160 lbs.	85
R12-ATH			59 kg	73 kg	
R12-ATI			90 lbs.	120 lbs.	
			41 kg	55 kg	
			90 lbs.	120 lbs.	
			41 kg	55 kg	

Model	(E) Electrical Requirements			
	Voltage	Total kW	Phase	Amps/Line
R12-ATG	208V/60Hz	5.0	1	24.0
	240V/60Hz	5.0	1	20.8
	480V/60Hz	5.0	1	10.4
R12-ATH	208V/60Hz	5.2	1	25.0
	240V/60Hz	5.2	1	21.7
	480V/60Hz	5.2	1	10.8
R12-ATI	-	-	-	-

## CAD SYMBOLS & PRICING



Due to continuous improvements, specifications subject to change without notice.



LANG MANUFACTURING • 10 SUNNEN DR. ST. LOUIS, MO 63143  
PHONE: 314-678-6315 • FAX: 314-781-3636 • www.langworld.com