

Model MCF14 & MCF18 Outdoor Fryer



Shown with optional
Dump Station

STANDARD ACCESSORIES

- Stainless steel positive latch cover w/Integral basket
- Tank-stainless steel
- Cabinet-stainless steel
- One tube rack
- Integral Flue Deflector
- Two twin size baskets
- One drain extension
- One drain line clean-out rod
- Two 14" (35.5 cm) wheels
- Two 9" (22.9 cm) locking casters
- 40 lbs vertical propane tank with Integral tank holder
- Two Basket hooks
- Integral latching tank lid/basket hanger

OPTIONS & ACCESSORIES (AT ADDITIONAL COST)

- Dump Station – includes 4" (10.1cm) deep pan and 2.5" (6.3 cm) perforated pan
- Removable Side Work Shelf
- Vinyl Cover



STANDARD SPECIFICATIONS CONSTRUCTION

- Welded tank with an extra smooth peened finish ensures easy cleaning.
- Long lasting, high temperature alloy stainless steel heat baffles are mounted in the heat exchanger tubes to provide maximum heating and combustion efficiency.
- Standing pilot light design provides a ready flame when heat is required.
- Stainless steel cabinet

MODELS AVAILABLE:

- MCF14 40 Lbs 115k BTU
- MCF18 65 Lbs 150k BTU

CONTROLS

- Thermostat maintains selected temperature automatically between 200°F (93°C) and 400°F (190°C).
- Integrated gas control valve acts as a manual and pilot valve, automatic pilot valve, gas filter, pressure regulator, and automatic main valve.
- Gas control valve prevents gas flow to the main burner until pilot is established and shuts off all gas flow automatically if the pilot flame goes out.
- Temperature limit switch safely shuts off all gas flow if the fryer temperature exceeds the upper limit.
- Pressure limit switch safely shuts off all gas flow if pressure in LP bottle drops below safe operating pressure.

OPERATIONS

- Front 1-1/4" NPT drain valve, for quick draining

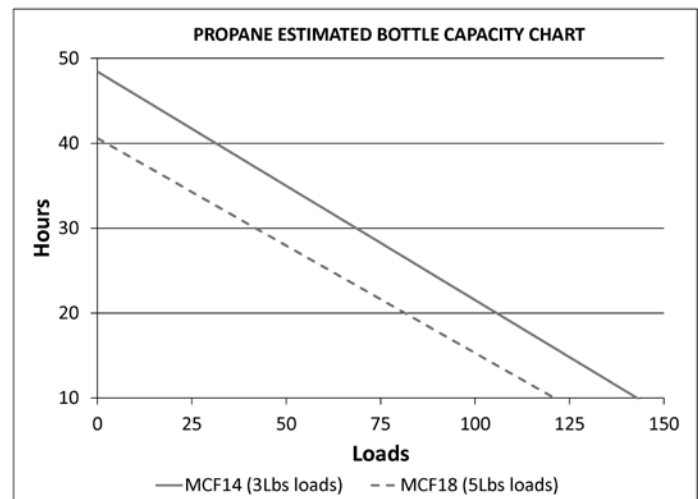

Model MCF14 & MCF18 Outdoor Fryer



Model MCF14 & MCF18 Outdoor Fryer

Model MCF14 & MCF18 Outdoor Fryer

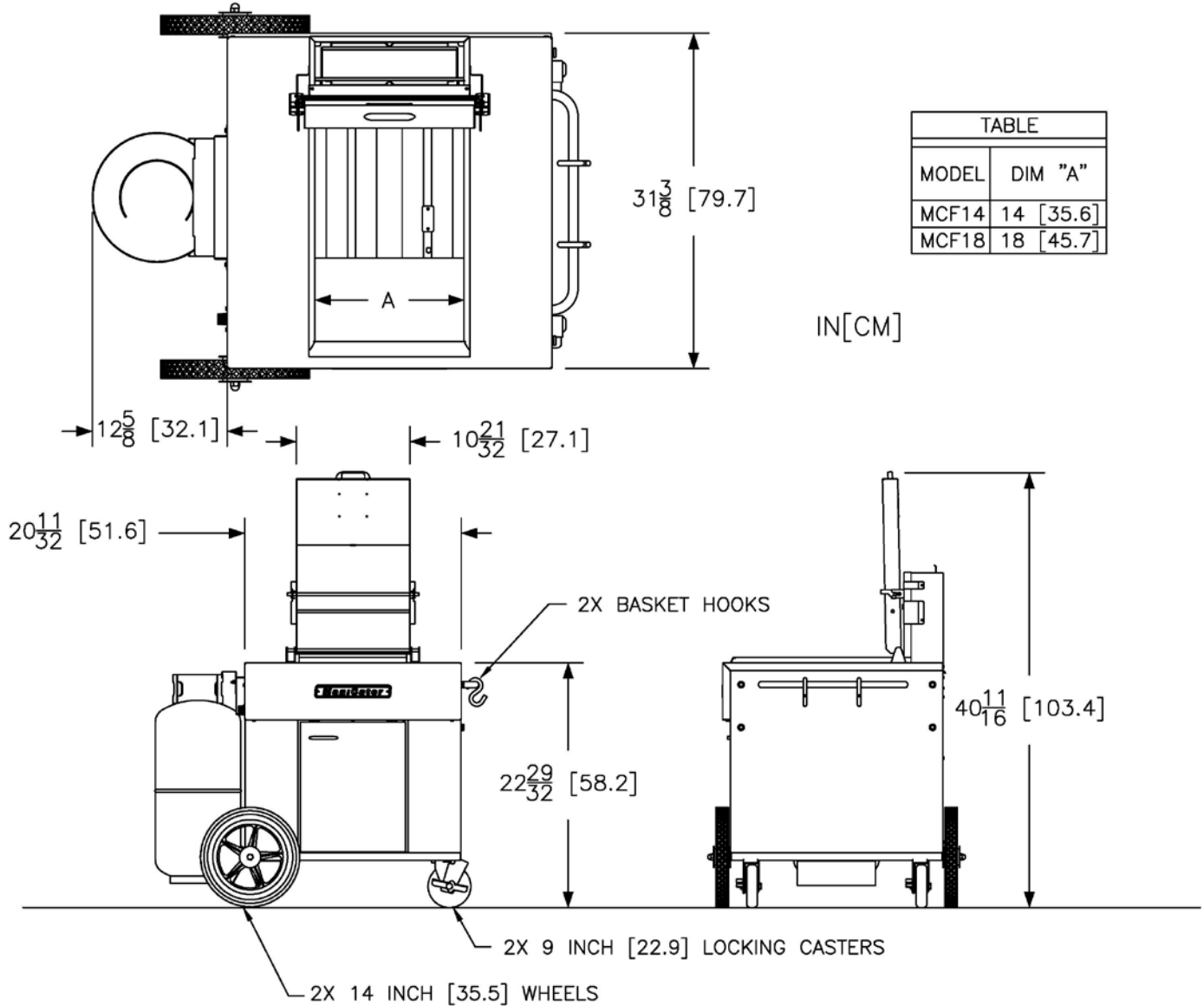

TABLE	
MODEL	DIM "A"
MCF14	14 [35.6]
MCF18	18 [45.7]

IN[CM]

INDIVIDUAL FRYER SPECIFICATIONS						
Models	Frying Area	Cook Depth	Oil Capacity	Gas Input Rate / Hr	Burner Pressure	
MCF14	14 x 14 in (35.6 x 35.6 cm)	3-1/4 - 5 in (8.3 - 12.7cm)	40 Lbs (18 kg)	115,000 BTUs (33.7 kW) (121 MJ)	10" W.C. (25 mbars (2.4 kPa))	
MCF18	18 x 18 in (45.7 x 45.7 cm)	3-1/4 - 5 in (8.3 - 12.7cm)	65 Lbs (29.4 kg)	150,000 BTUs (43.9 kW) (158 MJ)		
FRYER SYSTEM SHIPPING INFORMATION- Approximate						
Model	Shipping Weight	Shipping Crate Size H x W x L			Shipping Cube	
MCF14	335 Lbs (152 kg)	56 x 42 x 52 in (142.2 x 106.6 x 132.0 cm)			70.8 ft ³ (2.0 m ³)	
MCF18	455 Lbs (206 kg)					
CLEARANCES						
Front min.	Floor min.	Combustible material		Non-Combustible material		Fryer Flue Area
30" (76.2 cm)	6" (15.25 cm)	Sides min.	Rear min.	Sides min.	Rear min.	Do not block / restrict flue gases from flow ing into hood or install vent hood drains over the flue.
		6" (15.2cm)	6" (15.2cm)	0"	0"	



MagiKitch'n • P.O. Box 501, Concord, NH 03302-0501 • 509 Route 3A, Bow, NH 03304

603-225-6684 • FAX: 603-225-8497 • www.magikitch'n.com L10-399 Rev 0 09/12 Printed in the USA

We reserve the right to change specifications without notice and without incurring any obligation for equipment previously or subsequently sold