

QuietQube® i-976C Remote Ice Cube Machine

Air-Cooled Ice Cube Machine with Patented CVD Technology®

Model

- ID-0976C
 IY-0976C



ID-0976C Ice Cube Machine - 115V



CVD Condensing Unit - 230V



IY-0976C Ice Machine
on a B-570 Bin

QuietQube Series Remote System consists of a remote condensing unit, interconnecting refrigerant lines, ice machine head section along with an ice storage bin, countertop dispenser, or floor dispenser. All ordered separately. QuietQube ice machine with CVD condensing unit is designed as a Manitowoc system and cannot be used with any other ice machine or remote condenser brand. New Levels of Performance—showcasing improved ice harvest along with reductions in energy consumption.

- **ENERGY STAR** – the i976 exceeds ENERGY STAR standards and targets future energy efficiency standards.
- **Space-Saving Design** – Up to 816 lbs. (370 kgs.) daily ice production and only 30" (76.20 cm) wide.
- **Intelligent Diagnostics** – provide 24 hour preventative maintenance and diagnostic feedback for trouble free operation.
- **Acoustical Ice Sensing Probe** – for reliable operation in challenging water conditions.
- **EasyRead Display** – communicates operating status, cleaning reminders, and asset information through a blue illuminated display.
- **Programmable Ice Production** – by On/Off Time, Ice Volume or Bin Level (with accessory bin level control) further improves energy efficiency and savings.
- **Easy to Clean Foodzone** – Removable water-trough, distribution tube, splash shield, and sensing probes for fast and efficient cleaning. Select components made with AlphaSan® antimicrobial.
- **DuraTech™ Exterior** – provides superior corrosion resistance. Stainless finish with innovative clear-coat resists fingerprints and dirt.
- Available **LuminIce™ Growth Inhibitor** controls the growth of bacteria and yeast within the foodzone.

COMMERCIAL WARRANTY		
ICE MAKER	EVAPORATOR	COMPRESSOR
3	5	5
YEAR	YEAR	YEAR PARTS
PARTS AND LABOR		3 YEAR LABOR

Ice Shape



Half Dice
 $\frac{3}{8}'' \times 1\frac{1}{8}'' \times \frac{7}{8}''$
 (.95 x 2.86 x 2.22 cm)



Dice
 $\frac{7}{8}'' \times \frac{7}{8}'' \times \frac{7}{8}''$
 (2.22 x 2.22 x 2.22 cm)





i-976C Ice Machine

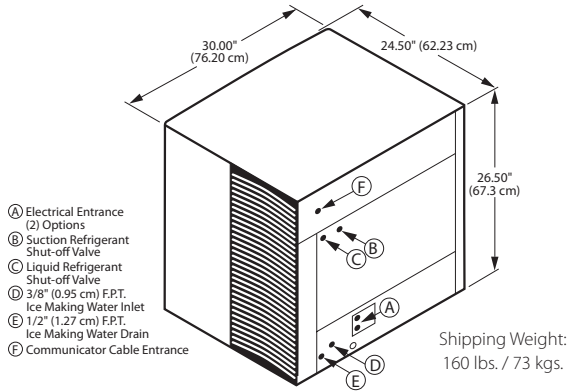

Specifications

Operating Limits:

- Ambient Temperature Range: 35° to 110°F (1.7° to 43.3°C)
- Water Temperature Range: 35° to 90°F (1.7° to 32.2°C)
- Water Pressure Ice Maker Water In: Min. 20 psi (137.9 kPa) Max. 80 psi (551.1 kPa)

Ice Machine Electric

115/60/1 standard. (230/50/1 also available, consult factory.)
Total Amps: 1.1
Max. fuse size: 15 amps
 HACR-type circuit breakers can be used in place of fuses.

AuCS® Accessory

Automatic Cleaning System purchased as an option and installed in the field.



iCVD-0996 Remote Condensing Unit

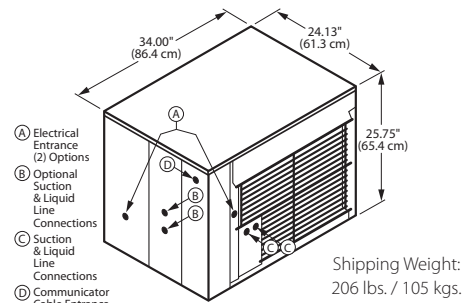

Condensing Unit Electric

208-230/60/1 standard. 208-230/60/3 and 230/50/1 also available. 50 Hz version of this model meets the international standard, IEC335-1, requirements for "tropical rating," the most severe duty rating an ice machine can obtain, (consult factory). HACR-type circuit breakers can be used in place of fuses.

Note: QuietQube ice machine power supply is wired independent of CVD condensing unit.

Min. circuit ampacity:

12.5 1ph 9.5 3ph

Max. fuse size:

20 amps 1ph 15 amps 3ph

HACR-type circuit breakers can be used in place of fuses.

BTU Per Hour:

12,700 (average) 14,800 (peak)

Compressor:

Nominal rating: 1.5 HP

Operating Limits:

- Ambient Temperature Range: -20° to 130°F (-29° to 54°C)

Installation Information and Dimensions:

Maximum Line Length
 —100' (30.5 m)*

Maximum Vertical Rise*
 —35' (10.7 m) above ice machine.

Maximum Vertical Drop
 —15' (4.5 m) below ice machine.

*A rise over 20' (6 m) requires S-Trap Kit K-00172 - ordered separately.

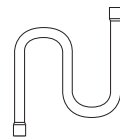

Interconnecting Tubing with Required Communication Wire*

Communication wire comes with each of the following line sets

Model	Line Length		Weight	
	ft.	m.	lbs.	kgs.
RC-26	20	6	12	5
RC-36	30	9	20	9
RC-56	50	15	28	13

*When using a non-Manitowoc line-set, a 186A 5-conductor communication cable must be installed between the head and condenser sections.

Remote Air-cooled Ice Machine

Model	Ice Shape	Ice Production 24 Hours		Power kWh/100 lbs* @ 90°/70°F
		70°Air/50°F Water	90°Air/70°F Water	
ID-0976C	dice	796 lbs.	696 lbs.	4.94
		361 kgs.	316 kgs.	
IY-0976C	half-dice	816 lbs.	714 lbs.	4.93
		370 kgs.	324 kgs.	
Water usage/100 lbs./45.4 kgs. of Ice				
Potable Water: 19 gallons, 71.9 liters				

Ice machine for use with ice storage bin or ice dispenser and ICVD condensing unit all ordered separately.

*kWh per 100 lbs. is total power of ice machine and condensing unit. Ice machine is 1 ph only. Condensing unit is 1 ph or 3 ph.